

Products and Systems for Energy Control and Monitoring



CATALOGUE 2015 – 2016



Content

Power Factor Correction 3



GCR06 / GCR12 – controller	5
FCR06 / FCR12 – controller	6
FCR05 / FCR07 – controller	7
FCR123 – controller	8
ICR12 – controller	9

Thyristor Switching Modules 11



CTU01 – switching module	12
CTU02 – switching module	12
CTU03 / CTU33 – switching module	13
Choke reactors for CTU modules	14
De-compensation reactors TTC	14

Energy Monitoring 15



PLA44 – power quality analyser class A	17
PLA34 – power quality analyser class S	19
PLA33 – power line analyser	21
PLA44RGP – portable power quality analyser class A	23
PLA404 – portable power quality analyser class S	24
HM2006 – peak maximum demand controller	25
Accessories	26
Power Monitoring Software	26

Modular Instruments 27



Multiple-function time relays	29
Voltage monitoring relays	31
Current monitoring relays	32
MRF1P – frequency monitoring relay	33
MTR01 – motor thermistor monitoring relay	34
MRL01 – liquid level monitoring relay	35
TR121 – multifunction differential thermostat	36
DTR01 – double thermostat	37
MSR01 – solar panel controller	38
HJ – main CB current controller	39

Introduction

From the year 1991, the Czech company BMR has been engaged in the development and production of instruments for the economical usage of electrical energy, monitoring and control. From the very beginning, BMR has been located in the town of Rychnov nad Kněžnou where the development and production facilities are located.

BMR started with the production of electronic regulators for direct electrical heating and advanced heating control systems. Thanks to the quality of production and experience obtained from the market, the development was systematically continued to areas. BMR then introduced instruments for measurement and the control of electrical energy.

Nowadays BMR is a well known manufacturer of measuring and controlling instruments in the field of power factor correction, class A power quality analysers, energy management systems, modular instruments and heating control systems.

Export

BMR trading was established in the year 2007 as an export division of BMR in order to be involved in foreign export and marketing events world wide. Nowadays BMR trading exports instruments around the whole world. The company is not only a sales office but also the team of engineers who actively participate in projects and provide technical support and help.

R&D

BMR has its own team of engineers and designers with much experience in the field. Research for new solutions and the development of new products are essential for bringing the best technology to our clients. Our R&D team allows us to be flexible regarding market requests, provide custom modifications for existing products and develop new solutions for special projects.

Quality control

BMR uses only electronic components of the highest quality and proven technology. Our products offer the best performance and functionality based on knowledge and experience of our production and designers. Every product is controlled several times during the production process and fully tested before final packaging.

BMR assures reliability, long working life and easy usage of every instrument that is delivered to the customer.

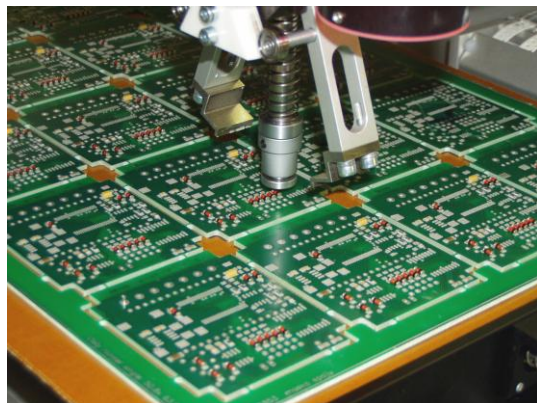

Power Factor Correction

An essential way of electrical energy cost reduction is the compensation of the reactive power caused by various type of loads. BMR offers a complete range of power factor controllers for usage in standard LV and MV applications, fast (dynamic) changing loads and special projects that require so called phase-compensation.

Thyristor switching modules for fast compensation, decompensation reactors and other instruments make a range of products for power factor correction complete.

Power Factor Controllers

The main part of central and group power factor correction in systems with a variable load is the power factor controller. A proper power factor controller and the correct design of PFC are key to the reduction of reactive energy costs. Nowadays, when four-quadrant energy meters are used, the right power factor controller is essential to achieve the highest efficiency of PFC system. Reliable, smart and advanced BMR controllers assure effective reduction of reactive energy and long working life of PFC systems.

Circular usage of steps

The controller switches all steps that have the same power circularly in order to use them equally and prolong their working life time.

Fast action

Optimal regulation is achieved in one regulation cycle with a minimum number of switched stages. Since the controller knows the needed compensation power, it can connect or disconnect several steps in one cycle.

Regulation methods

The power factor controller digitalizes measured phase voltage and phase current in one or three phases. From these values the controller then calculates power factor, effective values of voltage, current and powers. On the basis of allowed reactive power, which is set as a requested power factor value, the controller calculates the requested compensation power. In accordance with its size and direction, the controller connects or disconnects the appropriate steps.

APFR (average power factor regulation)

The controller quantifies an average power factor from active and apparent power over a defined period. This method assures that the controller reacts smartly to load changes taking into account the size of load and $\cos\phi$. Thanks to the APFR system, the power factor controller reduces the number of switching operations together with a precisely kept requested power factor result.

SHTD

This method uses the deceleration of time to reaction according to the size of the difference between the target power factor and instantaneous value. For every second of difference the time to the reaction is reduced by the square of difference until 0 (the moment of reaction).

Instantaneous power factor

This method reacts to every change of the instantaneous power factor by the connection or disconnection of the exact size of reactive power step. This method is mainly used for the dynamic power factor correction system based on thyristor switching modules.

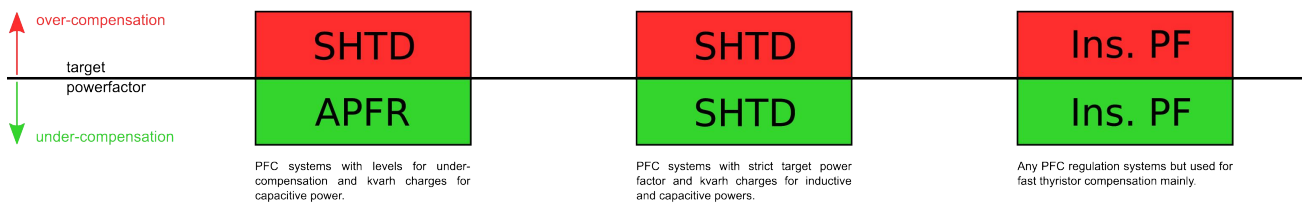

Ranges of power factor controllers

	Type	Number of controlled steps	Fast transistor steps	Measuring and supply voltage 400 V _{AC} *	Supply voltage 230 V _{AC} * / 100-690 V _{AC}	Graphic OLED display	LED segment display	Tariff input	Alarm output	Last step alarm output	3-ph current inputs	PF correction according energy meter impulses	DIN rail mounting	Panel mounting	RS485 interface	Parallel work of two controllers	Front panel dimensions
Standard LV and MV compensation	FCR05	6		•			•			•			○	•	○		97 x 97 mm
	FCR07	8		•			•			•			○	•	○		97 x 97 mm
	FCR06	6		•	○		•	•	•		○			•	○	○	144 x 144 mm
	FCR12	12		•	○		•	•	•		○			•	○	○	144 x 144 mm
	GCR06	6		•	○	•		•	•					•	○	○	144 x 144 mm
	GCR12	12		•	○	•		•	•					•	○	○	144 x 144 mm
	ICR12	12			○	•		•	•			•		•	○		144 x 144 mm
Fast and hybrid compensation	FCR06_xx	6	1 ... 6	•	○		•	•	•		○			•	○	○	144 x 144 mm
	FCR12_xx	12	1 ... 12	•	○		•	•	•		○			•	○	○	144 x 144 mm
	GCR06_xx	6	1 ... 6	•	○	•		•	•					•	○	○	144 x 144 mm
	GCR12_xx	12	1 ... 12	•	○	•		•	•					•	○	○	144 x 144 mm
	FCR123	12	12	•			•	•	•		•			•			144 x 144 mm

• – Default feature ○ – Optional feature * – Other voltages on request

Controller GCR06 and GCR12

The power factor controllers GCR06 and GCR12 combine features and functions of the power factor controller and the multifunction monitoring instrument. Thanks to the graphic OLED (organic light emitting diode) display, all information is shown at the same time for a faster overview and easy understanding about the PFC and grid situation. GCR controllers are designed for LV and MV application as well as for dynamic (fast) and hybrid thyristor power factor compensations.

Main characteristics

- monitoring of U, I, f, P, Q, S, cosφ, THDU, THDI, odd harmonics of U and I up to the 19th order, temperature
- three regulation methods (APFR default)
- graphic OLED display
- automatic and manual configuration of measuring circuit connection
- automatic and manual detection of connected capacitor steps
- universal CT input ..1A and ..5A
- cascade parallel operation of two controllers
- thyristor switchers control speed up to 25 operations per 1 second
- tariff activation by external input or current flow direction
- temperature sensor for ventilator and cabinet control
- ready for fast and hybrid thyristor dynamic compensation
- ready for applications with de-compensation reactors
- monitoring of switching operations and operation time
- memory for min. and max. values
- discharging time and min. operation time setting for each step
- programmable alarms and independent alarm output

Cascade operation

The two controllers in variant C can be connected together to expand the number of controlled steps or substitute for each other in a system with two main power supplies. Any one of the controllers can behave as a master or slave.

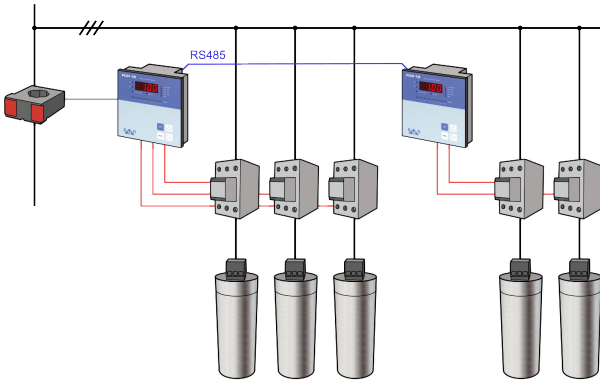

Technical features

Supply / measuring voltage	400 V _{AC} (+10%,-15%) 230 V _{AC} (+10%,-15%) / 100...690 V _{AC} 100 V _{AC} (+10%,-15%)
System frequency	50 Hz / 60 Hz
Power consumption	< 6 VA
Number of outputs	6 (GCR06) or 12 (GCR12)
Current range	3 mA ÷ 6 A
Current input accuracy	± 0.2%
Voltage input accuracy	± 0.5%
THDU and THDI accuracy	(U>10%U _N) ±5% / (I>10%I _N) ±5%
Phase error for I > 3% I _N	± 3° (otherwise ±1°)
Switching power of relay output	250 V _{AC} / 5 A
Switching power of transistor output	24 V _{DC} or 230 V _{AC} / 100 mA

Range of requested power factor	0.8 _{inductive} ÷ 0.8 _{capacitive}
Step reconnection delay	0 ÷ 900 s
Step disconnection delay	0 ÷ 900 s
Step power setting	999.9 kVAr _{inductive} ÷ 999.9 kVAr _{capacitive}
Switching speed of fast outputs	25 operations / 1 second
Communication interface	RS485 (Modbus RTU)
Working temperature	-25°C ÷ +70°C
Front panel dimensions	144 x 144 mm
Site depth	55 mm
Panel cutout	138 x 138 mm
Weight	1 kg (package including)
IP rating	IP20 rear, IP54 front panel
Related norms	EN 61010-1, EN50081-1, EN50082-1



OLED graphic display

The bright and fully graphic OLED display gives a new dimension to the power factor controller. It provides power monitoring functions so there is no need for an additional monitoring instrument or analogue meter.

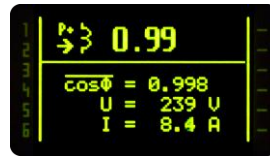

RS485 interface

The power factor controllers GCR06 and GCR12 can be optionally equipped with an RS485 communication interface with a communication protocol Modbus RTU.

Tariff input

The second tariff of requested cosφ can be activated by an external signal or by the current direction for application where consumption and distribution is present while distribution has a defined different level of cosφ.

Over temperature control

The controller offers the possibility of a temperature alarm working on two levels. The first level starts the ventilation of the cabinet. The second level disconnects all steps and gives an alarm notification on the display.

Controller FCR06 and FCR12

The power factor controllers FCR06 and FCR12 are well proven controllers for LV and MV applications as well as for fast and hybrid thyristor power factor correction applications. The power factor controllers FCR06 and FCR12 offer advanced functionality, the automatic detection of measuring circuits and capacitor steps, three-phase current measurement, and also reliability and design for the hardest conditions.

Main characteristics

- monitoring of U, I, f, P, Q, S, cosφ, THDU, THDI, odd harmonics of U and I up to the 19th order, temperature
- three regulation methods (APFR default)
- automatic and manual configuration of measuring circuit connection
- automatic or manual detection of connected capacitor steps
- universal CT input ..1A and ..5A
- cascade parallel operation of two controllers
- thyristor switcher control speed up to 25 operations per 1 second
- second tariff activation by external input or current direction
- internal temperature sensor
- adjustable temperature for cabinet disconnection
- ready for fast and hybrid thyristor compensation
- ready for applications with de-compensation reactors
- monitoring of switching operations and operation time
- memory for min. and max. values
- discharging time and min. operation time setting for each step
- programmable alarms and independent alarm output

Symbol menu

Every parameter in the monitoring and service menu is represented by a three or four character symbol. Symbols are logical and assure user friendly experience and an easy understanding of all parameters and measured values shown on the segment display.

Three-phase current measurement

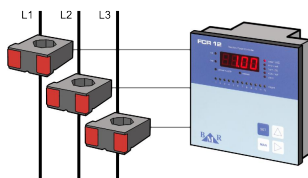

In unbalanced systems it is necessary to measure current in each phase and calculate needed compensation power from real three-phase powers. FCR06T and FCR12T controllers are available with three current inputs.

Dichromatic LED indication

Each step of the controller has an operation status indicated by a dichromatic LED. Different colours and logical signalization identify the operation status and settings of each step.

Technical features

Supply and measuring voltage	400 V _{AC} (+10%, -15%) 230 V _{AC} (+10%, -15%) / 100...690 V _{AC} 100 V _{AC} (+10%, -15%)
System frequency	50 Hz / 60 Hz
Power consumption	< 6 VA
Number of outputs	6 (FCR06) or 12 (FCR12)
Current range	3 mA ÷ 6 A
Accuracy of current input	± 0.2%
Accuracy of voltage input	± 0.5%
THDU and THDI accuracy	(U>10%U _N) ±5% / (I>10%I _N) ±5%
Phase error for I > 3% I _N	± 3° (otherwise ±1°)
Switching power of relay output	250 V _{AC} / 5 A
Switching power of transistor output	24 V _{DC} or 230 V _{AC} / 100 mA



De-compensation

The controllers FCR and GCR range have features for smart decompensation with several reactor steps operating in a similar way as capacitor steps or only one reactor that is tuned by capacitor steps.

Tariff input

The power factor controller has an input for the second tariff of cosφ. The value of the second tariff cosφ can be defined in the controller's service menu. Applying the signal to input activates the second tariff of cosφ.

RS485 interface

The power factor controllers FCR06 and FCR12 can be optionally equipped with the RS485 communication interface with communication protocol Modbus RTU.

Cascade operation

Two controllers in variant C can be connected together to expand the number of controlled steps or substitute for each other in a system with two main power supplies. Any one of controllers can behave as a master or slave.

Over temperature control

The controller offers the possibility of a temperature alarm working in two levels. The first level starts the ventilation of the cabinet. The second level disconnects all steps and gives an alarm notification on the display.

Range of requested cosφ	0.8 _{inductive} ÷ 0.8 _{capacitive}
Step reconnection delay	0 ÷ 900 s
Step disconnection delay	0 ÷ 900 s
Step power setting	999.9 kVAr _{inductive} ÷ 999.9 kVAr _{capacitive}
Switching speed of fast outputs	25 operations / 1 second
Communication interface	RS485 (Modbus RTU)
Working temperature	-40°C ÷ +70°C
Front panel dimensions	144 x 144 mm
Site depth	55 mm
Panel cutout	138 x 138 mm
Weight	1 kg
IP rating	IP20 rear, IP54 front panel
Related norms	EN 61010-1, EN50081-1, EN50082-1

Controller FCR05 and FCR07

Power factor controllers FCR05 (6 outputs) and FCR07 (8 outputs) are designed for usage in standard LV and MV power factor correction applications operated by mechanical contactors. Despite the small size of power factor controllers, they offer four quadrant measurement and regulation, automatic detection of measuring circuits and capacitor steps, high sensitivity, reliability and design for the hardest conditions.

Main characteristics

- monitoring of U, I, P, Q, S, $\cos\phi$, THDU, THDI, odd harmonics of U and I up to the 19th order, temperature
- three regulation methods (APFR default)
- small design 97 x 97 mm for pannel mounting
- controller type for panel and DIN rail mounting
- variant for supply - measuring voltage 230 V_{AC} and 400 V_{AC}
- automatic or manual configuration of measuring circuit connection
- automatic or manual detection of connected capacitor steps
- universal current transformer input ..1A and ..15A
- internal temperature sensor
- temperature levels for ventilator control and steps disconnection
- ready for applications with de-compensation reactor steps
- monitoring of switching operations and operation time
- setting of discharging and min. operation time for each step
- memory for min. and max. values
- discharging time and min. operation time setting for each step
- last step output programmable for alarm purposes

Over temperature control

The controller offers the possibility of the temperature alarm working in two levels. The first level starts the ventilation of the cabinet. The second level disconnects all steps and gives an alarm notification on the display.

DIN rail mounting type

Both types of the power factor controllers FCR05 and FCR07 are also available in the DIN rail mounting design. Displayed parameters, operation and technical features are the same for the panel mounting type. The dimension of the controller in the DIN rail design is 5 standard DIN modules.



Last step alarm output

The last step normally functions as a standard compensation step. Nevertheless it can be removed from the regulation algorithm and enabled for alarm purposes. The configuration of the last step operated as an alarm output is easily done in the setup menu.

Technical features

Supply and measuring voltage	400 V _{AC} (+10%, -15%) 230 V _{AC} (+10%, -15%)
System frequency	50 Hz / 60 Hz
Power consumption	< 3.2 VA
Number of outputs	6 (FCR05) or 8 (FCR07)
Current range	5 mA ÷ 6 A
Current input accuracy	± 0.2%
Voltage input accuracy	± 0.5%
THDU and THDI accuracy	(U>10%U _N) ±5% / (I>10%I _N) ±5%
Phase error for I > 3% I _N	± 3° (otherwise ±1°)
Switching power of relay output	250 V _{AC} / 5 A
Range of requested power factor	0.8 inductive ÷ 0.8 capacitive
Step reconnection delay	5 ÷ 900 s



Harmonics measurement

The controllers offer a wide range of monitoring features which are enlarged by THDU, THDI and also the particular odd harmonics of U and I up to the 19th order.

De-compensation

The controllers FCR and GCR range have features for smart decompensation with several reactor steps operated in a similar way as capacitor steps or only one reactor that is tuned by capacitor steps.

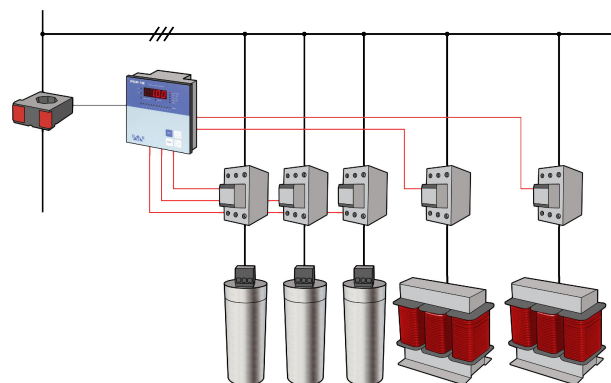

RS485 interface

The power factor controllers FCR05 and FCR07 can be, by request, delivered with the RS485 communication interface and communication protocol Modbus RTU.

Step disconnection delay	5 ÷ 900 s
Step power setting	999 kVAR _{inductive} ÷ 999 kVAR _{capacitive}
System connection detection	manual / automatic
Alarm output	programmable last step
Communication interface	RS485 (Modbus RTU)
Working temperature	-40°C ÷ +70°C
Front panel dimensions	97 x 97 mm
Site depth	50 mm
Panel cutout	91 x 91 mm
DIN variant dimensions	5 DIN modules
Weight	650 g
IP rating	IP20 rear, IP54 front panel
Related norms	EN 61010-1, EN50081-1, EN50082-1

Controller FCR123

The power factor controller FCR123 is designed for fast compensation of three-phase unbalanced systems. It is a powerful solution for power factor correction and voltage symmetrization in applications with unbalanced systems and in need of dynamic compensation such as welding plants and robotic assembling plants in the automotive industry.

FCR123 is a set of three FCR06-06 or FCR12-12 controllers with independent inputs for current measurement at each phase.

The FCR123 set of controllers work together with fast thyristor switching modules CTU33 for fast switching of up to 25 operations per second in each phase.



Main characteristics

- monitoring of U, I, f, P, Q, S, cosφ, THDU, THDI, odd harmonics of U and I up to the 19th order, temperature
- switching speed up to 25 operations per 1 second
- current measurement in all three phases
- current transformer input ..1A and ..5A
- 24 V_{DC} control voltage of transistor outputs
- panel mounting 144 x 144 mm design

Schematic connection diagram

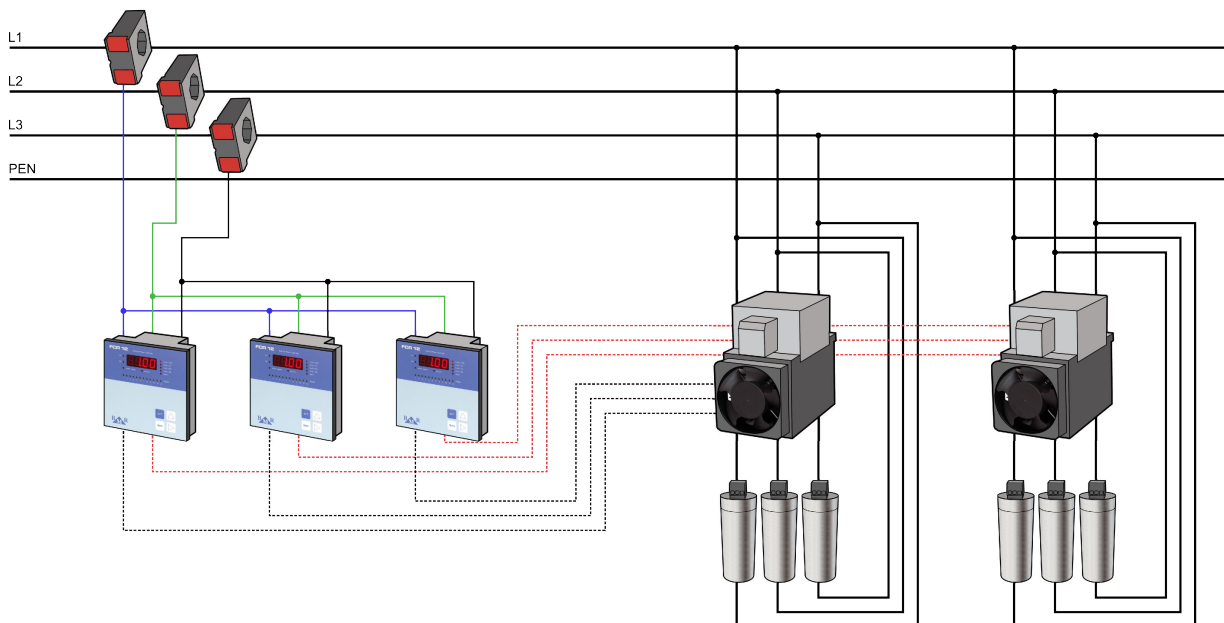

Technical features

Supply and measuring voltage	400 V _{AC} (+10%, -15%) 230 V _{AC} (+10%, -15%) 100 V _{AC} (+10%, -15%)
System frequency	50 Hz / 60 Hz
Power consumption	< 6 VA
Number of outputs	6 or 12
Current range	3 mA ÷ 6 A
Accuracy of current input	± 0.2%
Accuracy of voltage input	± 0.5%
THDU and THDI accuracy	(U>10%U _N) ±5% / (I>10%I _N) ±5%
Phase error for I > 3% I _N	± 3° (otherwise ±1°)
Switching power of transistor output	24 V _{DC} / 100 mA

Range of requested cosφ	0.8 _{inductive} ÷ 0.8 _{capacitive}
Step reconnection delay	0 ÷ 900 s
Step disconnection delay	0 ÷ 900 s
Step power setting	999.9 kVAR _{inductive} ÷ 999.9 kVAR _{capacitive}
Switching speed of fast outputs	25 operations / 1 second
Working temperature	-40°C ÷ +70°C
Front panel dimensions	144 x 144 mm
Site depth	55 mm
Panel cutout	138 x 138 mm
Weight	3 x 1 kg
IP rating	IP20 rear, IP54 front panel
Related norms	EN 61010-1, EN50081-1, EN50082-1

Controller ICR12

The impulse power factor controller ICR12 is designed for usage in applications where load variation between working times is too high to be measured by measuring current transformers. The ICR12 controller is also a solution for unbalanced systems where there is the possibility to take energy impulses directly from the utility static energy meter.

The controller ICR12 reads, directly or via the optical separation unit, pulses from the static energy meter. Based on the pulse weight and time distance between particular pulses, the controller calculates active and reactive powers. At low signal frequency of measuring pulses, the controller corrects power values depending on running time.

Main characteristics

- monitoring of P, Q, S, $\cos\phi$, temperature
- APFR regulation method
- built-in temperature sensor for ventilator and cabinet control
- adjustable temperature for ventilator control and cabinet disconnection
- four preset half-periods of APFR regulation 15, 30, 45, 60 minutes
- ready for applications with de-compensation reactor steps
- multiple information graphic OLED display
- monitoring of switching operation number
- memory for minimums and maximums of measured parameters
- discharging time and min. operation time setting for each step
- galvanic insulated pulse inputs
- internal supply unit for pulse inputs charging
- internal temperature sensor
- RS485 communication interface with Modbus RTU protocol

RS485 interface

The power factor controller ICR12 is available with an RS485 interface and communication protocol Modbus RTU for easy implementation into monitoring systems.

Internal power supply

The ICR12 controller has a built-in 12 V_{DC} power supply for supplying the energy meter pulse outputs. The internal power supply is fully metalically separated from the controller in order to assure the insulation of pulse outputs of the energy counter.

Over temperature control

The controller offers the possibility of the temperature alarm working in two levels. The first level starts the ventilation of the cabinet. The second level disconnects all steps and gives an alarm notification on the display.

Technical features

Supply voltage	230 V _{AC} (+10%, -15%)
System frequency	50 Hz / 60 Hz
Power consumption	< 6 VA
Number of outputs	12
Switching power of relay output	250 V _{AC} / 5A
Range of requested $\cos\phi$	0.8 _{inductive} ÷ 0.8 _{capacitive}
Stage reconnection delay	0 ÷ 900 s
Stage disconnection delay	0 ÷ 900 s
Pulse inputs S0	+P, -P, +Q, -Q, COM terminal
Maximum frequency of input pulses	10 Hz
Minimum pulse length	50 ms

Step power setting	999.9 kVA _{r inductive} ÷ 999.9 kVA _{r capacitive}
Connection and stage setting	manual
Power supply for pulse inputs	+/- 12 V _{DC}
Communication interface	RS485
Communication protocol	Modbus RTU
Working temperature	-25°C ÷ +70°C
Front panel dimensions	144 x 144 mm
Site depth	55 mm
Panel cutout	138 x 138 mm
Weight	1 kg
IP rating	IP20 rear, IP54 front panel



OLED graphic display

The bright and fully graphic OLED display gives a new dimension to power factor controller. It provides power monitoring functions so there is no need for additional monitoring instruments or analogue meter.



Schematic connection diagram

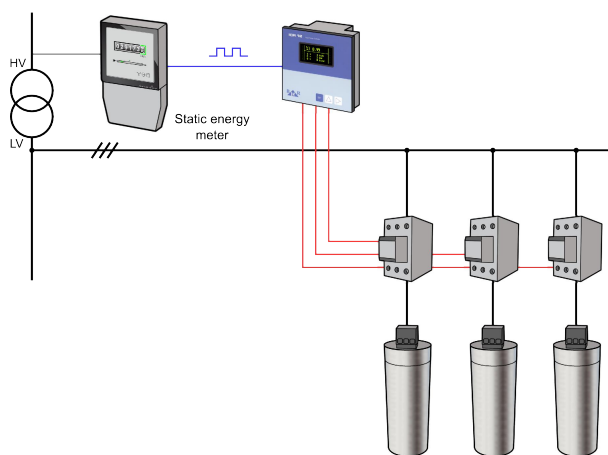

Variants codes of power factor controllers

GCR06 and GCR12

Instrument name	GCR	06	03	RS	V230
Number of outputs					
06	6 outputs				
12	12 outputs				
Number of transistor outputs					
–	no transistor outputs				
1 ... 6	outputs for GCR06				
1 ... 12	outputs for GCR12				
Communication interface RS485					
–	none				
RS	RS485 interface				
RSC	cascade of two controllers				
Supply / measuring voltage					
–	400 V _{AC} / 400 V _{AC}				
V230	230 V _{AC} / 100 ÷ 690 V _{AC}				
V100	100 V _{AC} / 100 V _{AC}				

FCR06 and FCR12

Instrument name	FCR	06	03	T	RS	V230
Number of outputs						
06	6 outputs					
12	12 outputs					
Number of transistor outputs						
–	no transistor outputs					
1 ... 6	outputs for FCR06					
1 ... 12	outputs for FCR12					
Three-phase current measurement						
–	1 phase current input					
T	3 phase current input					
Communication interface RS485						
–	none					
RS	RS485 interface					
RSC	cascade of two controllers					
Supply / measuring voltage						
–	400 V _{AC} / 400 V _{AC}					
V230	230 V _{AC} / 100 ÷ 690 V _{AC}					
V100	100 V _{AC} / 100 V _{AC}					

FCR05 and FCR07

Instrument name	FCR	05	DL	RS	V230
Number of outputs					
05	6 outputs				
07	8 outputs				
Mounting					
–	panel type				
DL	DIN rail TH35 type				
Communication interface RS485					
–	none				
RS	RS485 interface				
Supply / measuring voltage					
–	400 V _{AC} / 400 V _{AC}				
V230	230 V _{AC} / 230 V _{AC}				
V100	100 V _{AC} / 100 V _{AC}				

ICR12

Instrument name	ICR	12	RS	V100
Number of outputs				
12	12 outputs			
Communication interface RS485				
–	none			
RS	RS485 interface			
Supply voltage				
–	230 V _{AC}			
V100	100 V _{AC}			

Thyristor Switching Modules

The thyristor switching modules of CTU range were developed for usage in applications with fast load changes (welding plants, stamping plants, lifts, cranes, controlled drives, etc.). With such types of loads, the standard mechanical contactor operated PFC is not able to compensate the reactive power at the targeted power factor level.

Thyristor switching modules CTU01 and CTU02 are designed for switching capacitor steps in fast dynamic PFC application. The construction determines their usage in 3-phase systems with needs of fast reaction to the load changes.

CTU03 thyristor switching modules have been developed for the switching of 1-phase capacitors connected into a Δ or Y connection. Variants of the CTU33 thyristor switching modules offer independent control of 1-phase capacitors connected between phases to compensate reactive power and also to balance a 3-phase network.

Operation principle

Thyristor switching modules are constructed for the switching of L-C circuits with prevailing capacitive part (detuned compensation stages).

The advantage of thyristor modules of the CTU range compared to the classic mechanical contactor switching of capacitor steps is an immediate connection of the capacitor without its previous discharging. This is possible thanks to special construction which assures that the capacitor is ready for another connection immediately after its previous disconnection. The switching of the capacitor is achieved at the moment when the difference between the capacitor voltage and system voltage is equal to zero.

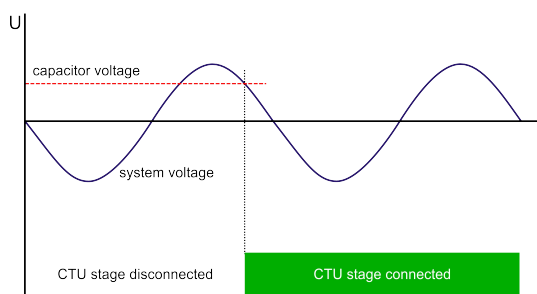

From this feature comes another important advantage and this is significant current surges reduction. Current surges cause disturbances which can affect proper running of electronic devices and can severely damage and even destroy them. Further more, the lifetime of capacitors is increased because only nominal current flows through the circuit. For the protection of the power switching element against current peaks (di/dt), it is necessary to connect the JTC inductor to the module.

Ranges of thyristor switching modules

Type	Switcher in L1, L2, L3	Switcher in L1 and L3	Max 3-ph. C power [kVAR]	Max 1-phase C power [kVAR]	Control voltage 230 V _{AC}	Control voltage 24 V _{DC}	Rated grid voltage 400 V _{AC} 50 Hz (+10%, -15%)*	Rated phase current [A]	Forced ventilation	Dimensions [mm]	Weight [kg]	
Thyristor switching modules for 3-phase capacitors	CTU 01-400-15	•	15		○	•	•	22		200 x 120 x 155	3.4	
	CTU 01-400-30	•	30		○	•	•	43		200 x 120 x 225	5.0	
	CTU 01-400-50	•	50		○	•	•	72	•	238 x 120 x 225	5.6	
	CTU 01-400-72	•	72		○	•	•	104	•	238 x 120 x 225	5.9	
	CTU 02-400-15	•		15		○	•	•	22		200 x 120 x 155	3.5
	CTU 02-400-30	•		30		○	•	•	43		200 x 120 x 225	5.1
	CTU 02-400-50	•		50		○	•	•	72	•	238 x 120 x 225	5.7
	CTU 02-400-72	•		72		○	•	•	104	•	238 x 120 x 225	6.0
Thyristor switching modules for 1-phase capacitors	CTU 03-400-10	•		3 x 6	○	•	•	15		200 x 120 x 155	3.5	
	CTU 03-400-30	•		3 x 17	○	•	•	43		200 x 120 x 225	5.1	
	CTU 03-400-50	•		3 x 30	○	•	•	72	•	238 x 120 x 225	5.7	
	CTU 03-400-72	•		3 x 42	○	•	•	104	•	238 x 120 x 225	6.0	

• – Default feature ○ – Optional feature * – Other voltages on the request

Switching modules for 3-phase capacitors

Thyristor switching modules for three-phase capacitors are made for fast speed compensation and also for smooth disturbance less operation. Modules are designed for easy construction of a PFC cabinet that follows the same rules as PFC cabinets based on standard mechanical contactors and three-phase capacitors protected by detuned reactors.

Control voltage variants

For easier assembling of the cabinet, two control voltages are offered. The standard and recommended 24 V_{DC} or an optional 230 V_{AC} preferred for hybrid power factor cabinets.

Over-temperature protection

Inside each CTU module there is a temperature sensor. If the temperature of this sensor exceeds 80°C then the control board disconnects all semiconductor switchers to protect the module against damage. For modules equipped with a ventilator, the sensor is also used for forced ventilation control.



CTU02 module with switcher in L1, L2, L3

The thyristor switching module CTU02 with maximum switching speed performance of 3-phase capacitors. Special construction solves voltage discharging time limitation so the three-phase capacitor can be switched again immediately after disconnection without prior discharging. Switching is completed within 10 ms of receiving the signal from the PF controller. Thanks to the construction, the effective operation speed can be up to 25 operations per 1 second.

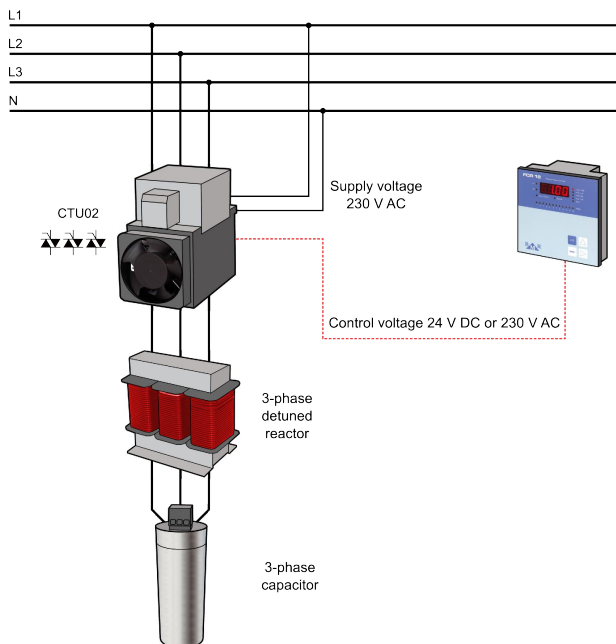

CTU01 module with switcher in L1 and L3

The thyristor switching module CTU01 is designed for smooth contactless switching of 3-phase capacitors. The connection of is completed within 10 ms of receiving the signal from the power factor controller. The maximum speed of reconnection is about 1 operation in 5 seconds, depending on the discharging resistors.

The typical application for usage of CTU01 modules are loads with periodical power changes every 10 – 30 seconds.

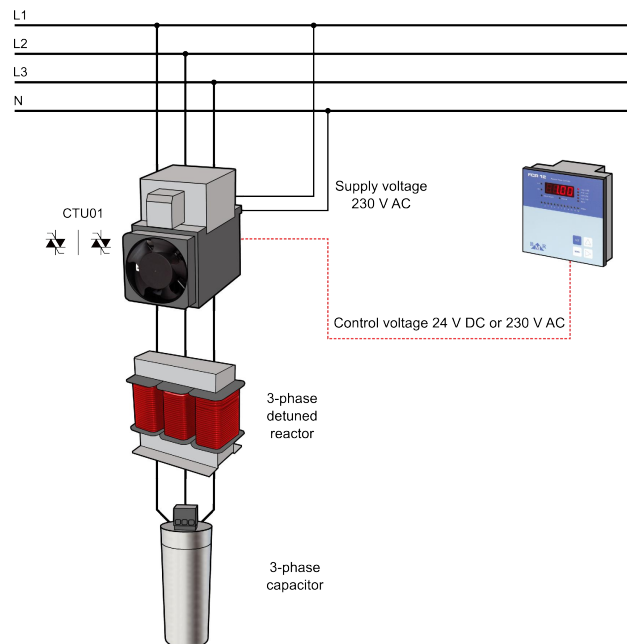

Technical features

System voltage	400 V _{AC} (+10%, -15%) - Δ connection
System frequency	50 Hz / 60 Hz
Auxiliary supply voltage	230 V _{AC} 50 Hz / 2 VA
Control voltage	24 V _{DC} or 230 V _{AC} 50 Hz
Power consumption of control input	0.24 VA
Reverse blocking voltage	1600 V
Temperature protection	internal +80°C
Type of switched load	R, C, LRC

Power dissipation	max. 60 / 150 / 250 / 300 W
Fan power consumption	3 VA
Working temperature	-25°C ÷ +45°C
Conductor size	35 mm ²
Supply voltage indication	green LED
Operating status indication	red LED in each phase
Mounting position	vertical and horizontal
IP rating	IP00

Switching modules for 1-phase capacitors

CTU03 / CTU33 modules for 1-phase capacitors

The range of thyristor switching modules CTU03 is designed for the switching of 1-phase capacitors connected to a Δ or Y connection. An advantage of CTU03 modules is the higher capacitive power that it can operate at. The maximum power is 126 kVAr per CTU03-400-72 module.

The variant CTU33 is equipped with 3 independent control inputs for operation by the controller FCR123.

Switching is completed within 10 ms from receiving the signal from power factor controller. This feature assures a switching speed up to 25 operations per 1 second.

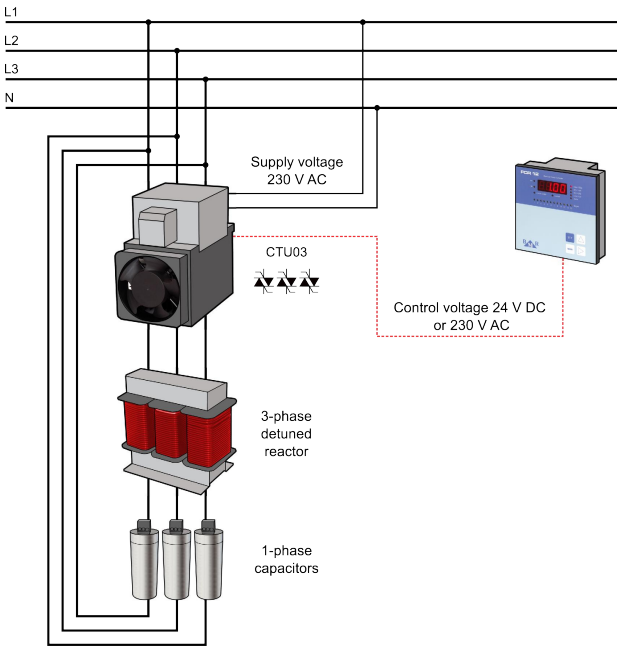

Optical signalization

Each phase has an LED signalization of its operating state to easily identify if the phase is connected or disconnected.

Over-temperature protection

Inside each CTU module there is a temperature sensor. If the temperature of this sensor exceeds 80°C, then the control board disconnects all semiconductor switchers to protect the module against damage. For modules equipped with a ventilator, the sensor is also used for forced ventilation control.

Technical features

System voltage	400 V _{AC} (+10%, -15%) - Δ connection 690 V _{AC} (+10%, -15%) - Y connection
System frequency	50 Hz / 60 Hz
Auxiliary supply voltage	230 V _{AC} 50 Hz / 2 VA
Control voltage	24 V _{DC} or 230 V _{AC} 50 Hz
Power consumption of control input	0.24 VA
Reverse blocking voltage	1600 V
Temperature protection	internal +80°C
Type of switched load	R, C, RLC

Power dissipation	max. 60 / 150 / 250 / 300 W
Fan power consumption	3 VA
Working ambient temperature	-25°C ÷ +45°C
Conductor size	35 mm ²
Supply voltage indication	green LED
Operating status indication	red LED for each phase
Mounting position	vertical and horizontal
IP rating	IP00
Supported controllers	FCR06/12, GCR06/12, FCR123

Variants codes of thyristor switching modules

Instrument name	CTU	02	400	50	V230
type of module					
01		switching element in L1 and L3			
02		switching element in L1, L2, L3			
03		module for 1-phase capacitors			
33		module for FCR123 controller			
Nominal network voltage					
400		400 VAC nominal voltage			
Nominal three-phase capacitor power					
Control voltage					
-		24 VDC control voltage			
V230		230 VAC control voltage			

Chooke reactors for CTU modules

One-phase current limiting reactor is designed for thyristor modules of the CTU series in conventional dynamic and hybrid PFC systems without detuned reactors. The JTC reactor is used for the limitation of the pace of current increase di/dt in the thyristors to the maximum permissible value.



Device type	System voltage [V]	Max 3-phase C power [kvar]	Rated current [A]	Inductance [mH]	Recommended thyristor module
JTC20	400	10	20	0.1	CTU01/CTU02/CTU03-400-10
JTC85	400	50	85	0.1	CTU01/02/03-400-30 CTU01/02/03-400-50
JTC110	400	72	110	0.1	CTU01/02/03-400-72

Technical features

System voltage	400 V _{AC} (+10%, -15%)
Inductance	0.1 mH
3-phase C power	10 kvar / 50 kvar / 72 kvar
Rated current	20 A / 85 A / 110 A
Current of linearity	30 A / 120 A / 160 A
I _{eff} rated current	22.2 A / 95 A / 122 A
Thermal current	30 A / 115 A / 150 A
Temperature class	ta 70°C/F

Power dissipation	25 W / 30 W / 40 W
Max. ambient temperature	+80°C
Weight	0.6 kg / 2 kg / 4 kg
IP rating	IP00
Related standards	EN 61558-2-20
Cu bus bar	2 x 20 mm
Cable screw diameter	Ø 7 mm / Ø 8.4 mm / Ø 8.4 mm
Mounting screw diameter	Ø 3.6 mm / Ø 4.6 mm / Ø 4.6 mm

De-compensation reactors TTC

The de-compensation reactor is an inductive ballast for eliminating the leading reactive power of a distribution system's parasitic elements (HV cables with metal shrouds, long power lines off-load etc.). Reactors are intended for 3x400V 50 Hz systems. Winding is made by copper or aluminium according to the reactive power size.

Reactors meet requirements of standard EN 60076-6 and EN 61558-2-20.

Reactors are produced in the standard range of 1.5 kvar to 100 kvar. Other power ratings (up to 500 kvar) or different voltage levels could be requested.



Energy Monitoring



The monitoring of electrical energy flow of particular parts of production, distribution boards and buildings is an essential tool for energy management. Precise measurement and further evaluation of gathered information is a base for energy cost reduction. BMR offers a wide range of network analysers and power quality analysers for designing powerful energy monitoring systems.

Network And Power Quality Analysers

Network analysers are designed to monitor electrical network parameters in LV and MV installations. The precise and continuous measurements of voltage and current inputs assure a high accuracy of all measured parameters for a complete range of analysers. All instruments are built with modern microprocessors that bring enough computing capabilities to provide various functions and connectivity for remote reading. Communication interfaces such as RS485, Ethernet, USB and several other protocols allow easy connection to other instruments, HMI and SCADA systems.

BMR offers a range of panel mounting instruments for line monitoring and also power quality analysis. For measurement on site, there are portable instruments designed for easy usage in the field.

Range of power line and quality analysers

Device type	 											
	PLA33L	PLA33C	PLA33CM	PLA33LDL	PLA33CDL	PLA33CMDL	PLA33CDL25A	PLA33CMDL25A	PLA34	PLA44	PLA44RGP	PLA404
Measuring voltage L-N, AC	10 ÷ 300 V			10 ÷ 300 V			10 ÷ 300 V		10 ÷ 600 V	10 ÷ 600 V	10 - 600 V	10 - 600 V
Measuring voltage L-L, AC	10 ÷ 520 V			10 ÷ 520 V			10 ÷ 520 V		18 ÷ 1000 V	18 ÷ 1000 V	18 - 1000 V	18 - 1000 V
Measuring current	0.01 ÷ 6 A			0.01 ÷ 6 A			2.5 ÷ 25 A		0.001 ÷ 6 A	0.001 ÷ 6 A	Rogowski coils	Rogowski coils
Neutral current measurement	calculated			calculated			calculated		•	•	•	•
Auxiliary voltage	230 V _{AC} / 110 V _{AC} / 24 V _{AC/DC}								85 ÷ 265 V _{AC/DC}	230 V _{AC} 85 ÷ 265 V _{AC/DC}	85 ÷ 265 V _{AC/DC}	85 ÷ 460 V _{AC/DC}
Voltage / Current inputs	3 / 3			3 / 3			3 / 3		3 / 4	4 / 4	4 / 4	4 / 4
Quadrants	4			4			4		4	4	4	4
Sampling frequency	6.4 kHz			6.4 kHz			6.4 kHz		40 kHz	40 kHz	40 kHz	40 kHz
Continuous measurement	•			•			•		•	•	•	•
Measurements per second	5			5			5		5	5	5	5
Effective value from periods 50/60Hz	10/12			10/12			10/12		10/12	10/12	10/12	10/12
Accuracy V/A	±0.5 %			±0.5 %			±0.5 %		±0.2 %	±0.1 %	±0.1 %	±0.2 %
Harmonics V/A	1 ÷ 19			1 ÷ 19			1 ÷ 19		1 ÷ 65	1 ÷ 65	1 ÷ 65	1 ÷ 65
THDU, THDI	•			•			•		•	•	•	•
Harmonics P, Q									•	•	•	•
Interharmonics									•	•	•	•
Asymmetry, unbalance, vectors									•	•	•	•
Events, transients									•	•	•	•
Flicker (short/long term)									•	•	•	•
Flash memory	512 MB			512 MB			512 MB		1 000 MB *	1 000 MB *	1 000 MB *	1 000 MB *
Clock	•			•			•		•	•	•	•
IEC 61000-4-30 class									S	A	A	S
EN 50160									•	•	•	•
RS485 interface	•			•			•		•	•	•	•
USB, Ethernet									•	•	•	•
Modbus gateway									•	•	•	•
Modbus TCP/IP, FTP, NTP									•	•	•	•
Modbus RTU	•			•			•		•	•	•	•
Temperature sensor input									•	•	○	
Digital input / output / pulseoutput	2			2			2		2	2	2	2

• – Default feature ○ – Optional feature * – Larger memory on the request

Power quality analyser PLA44 class A

Power quality analyser are designed according to the norm EN 61000-4-30 class A with four voltage and current inputs for continuous measurement of electrical parameters in LV and MV systems for further power quality investigation. The PLA44 is built with a powerful RISC processor that provides sufficient processing capabilities for real-time measurement and calculation of all parameters and values.

Continuous sampling of the voltage and current inputs at 40 kHz, guarantees the highest accuracy. The PLA44 is the instrument for power quality monitoring according to EN 50160 of the incoming energy supply side as well as on the consumer side in order to find and analyse the root cause of network problems.

Main characteristics

- IT, TN, TT networks, 3 and 4-phase networks
- power quality measurement according the EN 61000-4-30 class A
- continuous sampling of voltage and current inputs at 40 kHz
- 4 voltage measuring inputs and 4 current measuring inputs
- Fourier analysis from 1st to 65th harmonics of U_{L-N} , U_{L-L} , I , P (+/-) and Q (L/C)
- harmonics, inter-harmonics of U_{L-N} , U_{L-L} , I according to EN 61000-4-7
- short and long term flicker according the EN 61000-4-15 class A
- transients detection > 25 μ s
- detection of events > 10 ms
- measured data logger, event and transient memory 1GB flash
- RS485, Ethernet, USB
- Ethernet gateway
- 2 digital inputs / outputs
- additional digital and analogue outputs and inputs via RS485 expansion module
- web-server and email notification for alarms and events

Communication

PLA44 offers USB, RS485, Ethernet interfaces with several communication protocols.

Modbus (RTU, TCP, Gateway), TCP/IP, HTTP (web-server), FTP, TFTP, NTP (time synchronisation), SMTP (email notifications).

Data memory

Flash memory 1GB for measured parameters, events, transients, load profiles and energy meters with user partition definition.

External temperature sensor

Independent input for external temperature NTC sensor which can be used for temperature monitoring at various locations.

Digital inputs and outputs

Two digital inputs/outputs configurable as logical input or output, alarm outputs, energy meter pulse outputs and remote controlled outputs.



EN50160 power quality analysis

PLA44 has the capability to record all parameters for evaluation of voltage power quality according EN50160 norm.

Ethernet - Modbus gateway

Thanks to a built-in Modbus TCP/IP converter it is possible use PLA44 as an Ethernet - Modbus gateway for connection of instruments with RS485 interface and Modbus RTU protocols.

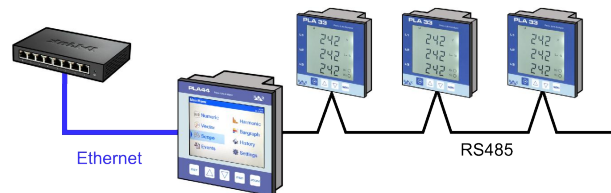

Web-server

Internal web-server for remote on-line monitoring designed with portable instruments web browsers HTML 5 support.

E-mail notification

Various alarms, events, RVC and transients can provoke an e-mail notification sent directly from the PLA44 instrument.

Graphic display

Large and bright 5.7" full graphic TFT display with a VGA resolution of 640 x 480 px for comfortable operation and readings.

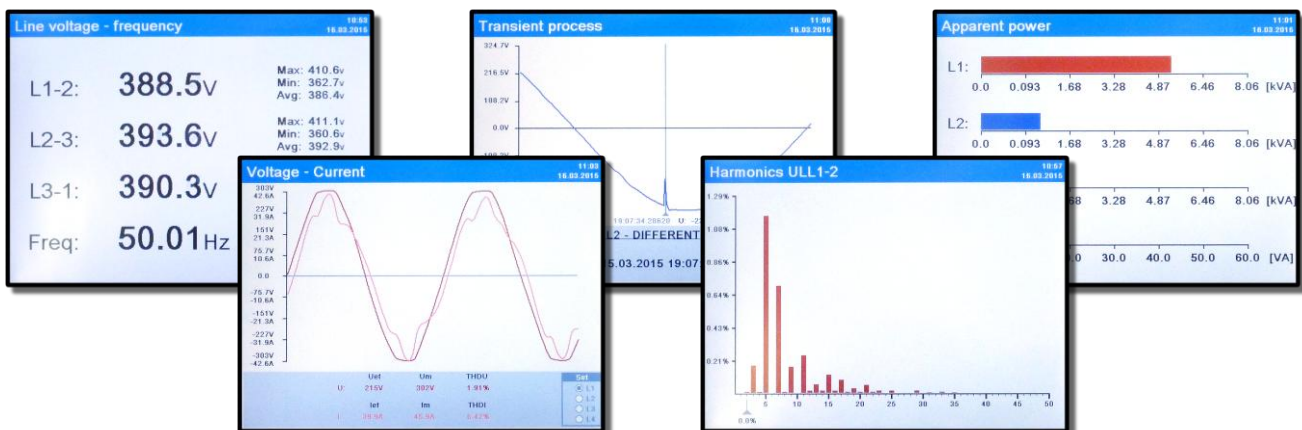

Measured parameters

Parameter	L1	L2	L3	L4	L1-L2	L2-L3	L3-L1	Σ L1-3	Σ L1-4	Max	Min	AVG	Measuring range	Displayed range	Accuracy
Phase voltage	•	•	•	•						•	•	•	10 ... 600 V	0 ... 1 MV	±0.1 %
Line voltage					•	•	•			•	•	•	18 ... 1000 V	0 ... 1 MV	±0.1 %
Frequency	•									•	•	•	40 ... 70 Hz	40 ... 70 Hz	±10 mHz
Current	•	•	•	•				•	•	•	•	•	0.001 ... 6 (8.5) A	0 ... 1 MA	±0.1 %
Cosφ	•	•	•	•						•	•	•	0.01 L ... 0.01 C	0.01 L ... 0.01 C	±1 %
Power factor	•	•	•	•				•	•	•	•	•	0.01 L ... 0.01 C	0.01 L ... 0.01 C	±1 %
THDU L-N	•	•	•	•						•	•	•	0 ... 99.9 %	0 ... 99.9 %	±1 %
THDU L-L					•	•	•			•	•	•	0 ... 99.9 %	0 ... 99.9 %	±1 %
THDI	•	•	•	•						•	•	•	0 ... 99.9 %	0 ... 99.9 %	±1 %
Harmonics U	•	•	•	•						•	•	•	0 ... 99.9 %	0 ... 99.9 %	class 1
Group of interharmonics U	•	•	•	•									0 ... 99.9 %	0 ... 99.9 %	class 1
Group of harmonic U	•	•	•	•									0 ... 99.9 %	0 ... 99.9 %	class 1
Harmonics P	•	•	•	•									0 ... 99.9 %	0 ... 99.9 %	class 1
Harmonics Q	•	•	•	•									0 ... 99.9 %	0 ... 99.9 %	class 1
Harmonics I	•	•	•	•						•	•	•	0 ... 99.9 %	0 ... 99.9 %	class 1
Group of interharmonics I	•	•	•	•									0 ... 99.9 %	0 ... 99.9 %	class 1
Group of harmonics I	•	•	•	•									0 ... 99.9 %	0 ... 99.9 %	class 1
Short term flicker	•	•	•	•						•	•	•	0 ... 20.0 Pst	0 ... 20.0 Pst	class A
Long term flicker	•	•	•	•						•	•	•	0 ... 20.0 Plt	0 ... 20.0 Plt	class A
Undervoltage U	•	•	•	•	•	•	•			•	•	•	0 ... 100%	0 ... 100 %	±0.2 %
Overvoltage U	•	•	•	•	•	•	•			•	•	•	0 ... 100%	0 ... 100 %	±0.2 %
Unbalance U										•	•	•	0 ... 100%	0 ... 100 %	±0.15 %
Neutral point displacement										•	•	•	10 ... 600 V	0 ... 1 MV	±0.2 %
K-factor	•	•	•	•											
Unbalance I										•	•	•			±0.5 %
Transients	•	•	•	•											25 μs
Events	•	•	•	•											10 ms
Ripple control signal	•	•	•	•	•	•	•			•	•	•			
Active power	•	•	•	•				•	•	•	•	•	0 ... 15.3 kW	0 ... 999 GW	±0.4 %
Reactive power	•	•	•	•				•	•	•	•	•	0 ... 15.3 kvar	0 ... 999 Gvar	±0.4 %
Apparent power	•	•	•	•				•	•	•	•	•	0 ... 15.3 kVA	0 ... 999 GVA	±0.2 %
Distortion power	•	•	•	•				•	•	•	•	•			±0.5 %
Active energy +/-	•	•	•					•					0 ... 999 GWh	0 ... 999 GWh	0.5S
Inductive energy +/-	•	•	•					•					0 ... 999 Gvarh	0 ... 999 Gvarh	class 1
Capacitive energy +/-	•	•	•					•					0 ... 999 Gvarh	0 ... 999 Gvarh	class 1
Temperature										•	•	•			±1°C

Technical features

Supply voltage	230 V _{AC} (+10%, -15%) 85 ÷ 265 V _{AC/DC}
System frequency	50 Hz / 60 Hz
Power consumption	max. 8 VA
Voltage measuring range L-N / L-L	10 ÷ 600 V _{AC} / 18 ÷ 1000 V _{AC}
Current measuring range	1 mA ÷ 6 A
Frequency measuring range	40 ÷ 70 Hz
Clock uncertainty	< 1 s per day
Number of output/input	2 programmable
Output type	insulated transistor 24 V _{DC} / 100 mA
Input type	optical insulated free potential
Input load capability	24 V _{DC} / 10 mA
Sampling frequency	40 kHz
Temperature input	NTC 10 kΩ / 25°C
Display	5.7" TFT VGA (640x480px)

Measuring transformer ratio of U and I	1 ÷ 1500
Communication interface	RS485, LAN, USB
Communication protocol	Modbus (RTU, TCP), TCP/IP, FTP, HTTP, SMTP, NTP
RS485 communication speed	9.6 ÷ 57.6 kBd
Overvoltage class	600 V CAT III
Pollution degree	2
Ambient temperature	-30°C ÷ +70°C
Front panel dimensions	144 x 144 mm
Site depth	65 mm
Cutout dimensions	138 x 138 mm
Weight	1 kg
IP rating	IP20 rear, IP54 front panel
Related standards	EN 61000-4-30 A, EN 61000-4-15, EN 61000-4-7, EN 61557-12

Power quality analyser PLA34 class S

A power quality analyser designed according the norm EN 61000-4-30 class S with three voltage and four current inputs for measurement of electrical parameters in LV and MV systems. PLA34 is built on a 32 bit RISC processor that provides sufficient processing capabilities for real-time measurement and calculation of all parameters & values. Continuous sampling of the voltage and current inputs at 40 kHz guarantees the highest accuracy. The PLA34 is an instrument for power quality monitoring according to the norm EN 50160. It can be used on the energy supplier side as well as on the consumer side in order to find and analyse the root cause of network problems.



- IT, TN, TT networks, 3 and 4-phase networks
- measurement of power quality according the EN 61000-4-30 class S
- continuous sampling of voltage and current inputs at 40 kHz
- 3 voltage measuring inputs and 4 current measuring inputs
- Fourier analysis from 1st to 65th harmonics of U_{L-N} , U_{L-L} , I , $P_{(+/-)}$ and $Q_{(L/C)}$
- harmonics, inter-harmonics of U_{L-N} , U_{L-L} , I according to EN 61000-4-7
- short term and long term flicker measurement according to the EN 61000-4-15
- detection of transients > 25 μ s
- detection of events > 10 ms
- measured data logger, event and transient memory 1GB flash
- communication interfaces RS485, Ethernet, USB
- Ethernet-Modbus gateway
- 2 digital inputs / outputs
- additional digital and analogue outputs / inputs via RS485 expansion module
- universal auxiliary supply voltage input $85 \pm 265 V_{AC/DC}$
- web-server and email notification for alarms and events

Communication

PLA34 offers USB, RS485 and Ethernet interfaces with several communication protocols.

Modbus (RTU, TCP, Gateway), TCP/IP, HTTP (web-server), FTP, TFTP, NTP (time synchronisation), SMTP (email notifications).

E-mail notification

Various alarms, events, RVC and transients can trigger an e-mail notification directly sent from the PLA34 instrument.

PLA34RGP portable version

The power quality analyser with inputs for current measurement via Rogowski coils is also available in a small portable version for service measurements on site. PLA34RGP is delivered with four Rogowski coils and textile bag for easy transport.



Ethernet - Modbus gateway

Thanks to the built-in Modbus TCP/IP converter it is possible use the PLA34 as an Ethernet - Modbus gateway for the connection of instruments with RS485 interfaces and Modbus RTU protocols.

Digital inputs and outputs

Two digital inputs/outputs configurable as logical input or output, alarm outputs, energy meter pulse outputs and remote controlled outputs.

Rogowski coils variant

PLA34 is available in the variant with inputs for Rogowski coils. Digital integrator for current range change is integrated inside the instrument PLA34RG.



Internal digital integrators offers the following measuring current ranges 10 A, 30 A, 100 A, 300 A, 1 kA, 3 kA, 10 kA

Data memory

Internal flash memory of 1 GB is used for recording measured parameters, events, transients, load profiles and energy meters. Measured parameters can be recorded in 5 time intervals defined by the user.

EN 50160 power quality analysis

PLA34 has the capability to record all parameters for the evaluation of voltage power quality according to the norm EN 50160. The EN 50160 controlled parameters and their intervals are predefined in a special template for easy setting. Via software there is the possibility to prepare a complete report for period defined by the user.

Web-server

The instrument has an internal web-server for the remote real-time monitoring of most of measured parameters. The web-server has been designed primarily for portable instruments with web browsers and HTML 5 support.

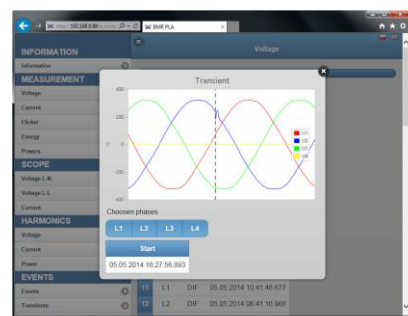
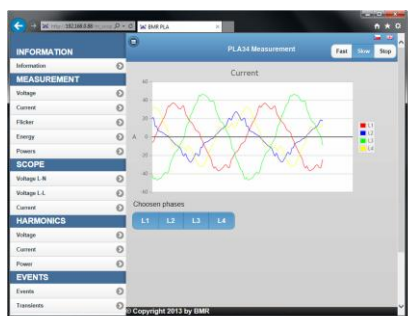
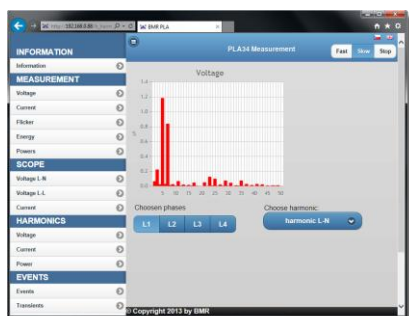

Measured parameters

Parameter	L1	L2	L3	N	L1-L2	L2-L3	L3-L1	Σ L1-L3	Max	Min	AVG	Measuring range	Displayed range	Accuracy
Phase voltage	•	•	•						•	•	•	10 ... 600 V	0 ... 1 MV	±0.2 %
Line voltage					•	•	•		•	•	•	18 ... 1000 V	0 ... 1 MV	±0.2 %
Frequency	•								•	•	•	40 ... 70 Hz	40 ... 70 Hz	±10 mHz
Current	•	•	•	•				•	•	•	•	0.001 ... 6 (8.5) A	0 ... 1 MA	±0.2 %
Cosφ	•	•	•						•	•	•	0.01 L ... 0.01 C	0.01 L ... 0.01 C	±1 %
Power factor	•	•	•					•	•	•	•	0.01 L ... 0.01 C	0.01 L ... 0.01 C	±1 %
THDU L-N	•	•	•						•	•	•	0 ... 99.9 %	0 ... 99.9 %	±5 %
THDU L-L					•	•	•		•	•	•	0 ... 99.9 %	0 ... 99.9 %	±5 %
THDI	•	•	•	•					•	•	•	0 ... 99.9 %	0 ... 99.9 %	±5 %
Harmonics U	•	•	•						•	•	•	0 ... 99.9 %	0 ... 99.9 %	class 1
Group of interharmonics U	•	•	•									0 ... 99.9 %	0 ... 99.9 %	class 1
Group of harmonic U	•	•	•									0 ... 99.9 %	0 ... 99.9 %	class 1
Harmonics P	•	•	•									0 ... 99.9 %	0 ... 99.9 %	class 1
Harmonics Q	•	•	•									0 ... 99.9 %	0 ... 99.9 %	class 1
Harmonics I	•	•	•	•					•	•	•	0 ... 99.9 %	0 ... 99.9 %	class 1
Group of interharmonics I	•	•	•	•								0 ... 99.9 %	0 ... 99.9 %	class 1
Group of harmonics I	•	•	•	•								0 ... 99.9 %	0 ... 99.9 %	class 1
Short term flicker	•	•	•						•	•	•	0 ... 20.0 Pst	0 ... 20.0 Pst	class A
Long term flicker	•	•	•						•	•	•	0 ... 20.0 Plt	0 ... 20.0 Plt	class A
Undervoltage U	•	•	•		•	•	•		•	•	•	0 ... 100%	0 ... 100 %	±0.2 %
Overvoltage U	•	•	•		•	•	•		•	•	•	0 ... 100%	0 ... 100 %	±0.2 %
Unbalance U									•	•	•	0 ... 100%	0 ... 100 %	±0.15 %
Neutral point displacement									•	•	•	10 ... 600 V	0 ... 1 MV	±0.2 %
K-factor	•	•	•											
Unbalance I									•	•	•			±0.5 %
Transients	•	•	•											25 μs
Events	•	•	•											10 ms
Ripple control signal	•	•	•		•	•	•		•	•	•			
Active power	•	•	•					•	•	•	•	0 ... 10.8 kW	0 ... 999 GW	±0.4 %
Reactive power	•	•	•					•	•	•	•	0 ... 10.8 kvar	0 ... 999 Gvar	±0.4 %
Apparent power	•	•	•					•	•	•	•	0 ... 10.8 kVA	0 ... 999 GVA	±0.4 %
Distortion power	•	•	•					•	•	•	•			±0.5 %
Active energy +/-	•	•	•					•				0 ... 999 GWh	0 ... 999 GWh	class 1
Inductive energy +/-	•	•	•					•				0 ... 999 Gvarh	0 ... 999 Gvarh	class 2
Capacitive energy +/-	•	•	•					•				0 ... 999 Gvarh	0 ... 999 Gvarh	class 2

Technical features

Supply voltage	85 ÷ 265 V _{AC/DC}
System frequency	50 Hz / 60 Hz
Power consumption	max. 4 VA
Voltage measuring range L-N / L-L	10 ÷ 600 V _{AC} / 18 ÷ 1000 V _{AC}
Current measuring range	1 mA ÷ 6 (8.5) A
Frequency measuring range	40 ÷ 70 Hz
Clock uncertainty	< 1 s per day
Number of output/input	2 programmable
Output type	insulated transistor 24 V _{DC} / 100 mA
Input type	optical insulated free potential
Input load capability	24 V _{DC} / 10 mA
Sampling frequency	40 kHz
Measuring transformer ratio of U and I	1 ÷ 750 000
Display	LCD

Communication interface	RS485, LAN, USB
RS485 communication speed	9.6 ÷ 57.6 kBd
Communication protocol	Modbus (RTU, TCP), TCP/IP, FTP, HTTP, SMTP, NTP
Overvoltage class	600 V CAT III
Pollution degree	2
Ambient temperature	-25°C ÷ +60°C
Front panel dimensions	96 x 96 mm
Site depth	75 mm
Cutout dimensions	92 x 92 mm
Weight	525 g
IP rating	IP20 rear, IP54 front panel
Related standards	EN 61000-4-30 S, EN 61000-4-15, EN 61000-4-7, EN 61557-12

Universal analyser PLA33

The power line analyser for accurate monitoring of main electrical parameters in three-phase or single-phase networks. The instrument measures continuous voltage and current according to the norm EN 61000-4-30. Thanks to precise measurement and a high sampling rate, it is also ideal for particular measuring points in electrical energy monitoring systems. The communication interface RS485 with Modbus RTU protocol predefine PLA33 can be used as a measuring point in SCADA systems.

- TN, TT, IT (virtual resistor N) 3 phase networks
- 3 voltage and 3 current inputs
- calculated current of neutral wire
- continual sampling frequency 6.4 kHz
- THD U and THD I measurement
- odd harmonics of U and I till 19th order (L1, L2, L3)
- power factor (L1) and $\cos\phi$ (L1, L2, L3)
- P+/-, Q+/-, S (L1, L2, L3, Σ)
- $E_{\text{active } +/-}$, $E_{\text{reactive L } +/-}$, $E_{\text{reactive C } +/-}$
- measurement according to the standard EN 61000-4-30
- measuring phase-phase voltage from 0 ... 520 V_{AC}
- memory for maximums / minimums of avg values
- memory for recording of last 20 supply voltage interruptions
- real-time clock with supercap backup
- communication interface RS485 with Modbus RTU protocol
- internal flash memory for measured parameters recording
- memory recording sampling period 1 ÷ 60 minutes
- two programmable digital inputs / outputs

Digital inputs and outputs

Two digital inputs/outputs are configurable as logical input or output, alarm outputs, energy meter pulse outputs and remote controlled outputs.

DIN rail variant

The PLA33 is also designed in a variant for DIN rail mounting installation. The instrument PLA33DL has exactly the same features and functions as a panel variant.



Measured parameters

Parameter	L1	L2	L3	N	L1-2	L2-3	L3-1	Σ L1-3	AVG	AVG _{max}	AVG _{min}	Measuring range	Displayed range	Accuracy
Phase voltage (L-N)	•	•	•						•	•	•	10 ... 300 V	0 V ... 180 kV	±0.5 %
Line voltage (L-L)					•	•	•		•	•	•	10 ... 520 V	0 V ... 312 kV	±0.5 %
Frequency	•								•	•	•	40 ... 70 Hz	40 ... 70 Hz	±50 mHz
Current	•	•	•						•	•	•	0.01 ... 6 A	0 ... 7.5 kA	±0.5 %
Current in neutral calculated				•					•	•	•	-	0 ... 7.5 kA	±0.5 %
Cosφ	•	•	•					•	•	•	•	0.01 _L ... 0.01 _C	0.01 _L ... 0.01 _C	±1 %
Power factor								•	•	•	•	0.01 _L ... 0.01 _C	0.01 _L ... 0.01 _C	±1 %
Voltage THD (THDU L-N)	•	•	•						•	•	•	0 ... 99.9 %	0 ... 99.9 %	±5 %
Current THD (THDI)	•	•	•						•	•	•	0 ... 99.9 %	0 ... 99.9 %	±5 %
Harmonics U, odd up to 19 th	•	•	•						•	•	•	0 ... 99.9 %	0 ... 99.9 %	±5 %
Harmonics I, odd up to 19 th	•	•	•						•	•	•	0 ... 99.9 %	0 ... 99.9 %	±5 %
Apparent power (S)	•	•	•					•	•	•	•	0 ... 5.4 kVA	0 ... 999 MVA	±0.8 %
Active power (P _{+/.})	•	•	•					•	•	•	•	0 ... 5.4 kW	0 ... 999 MW	±0.8 %
Reactive power (Q _{+/.})	•	•	•					•	•	•	•	0 ... 5.4 kVAr	0 ... 999 kVAr	±1 %
Active energy +/-								•				0 ... 9 999 999 kWh	0 ... 9 999 999 kWh	class 1
Inductive energy +/-								•				0 ... 9 999 999 kVArh	0 ... 9 999 999 kVArh	class 2
Capacitive energy +/-								•				0 ... 9 999 999 kVArh	0 ... 9 999 999 kVArh	class 2
Supply voltage interruptions												< 1 s	< 1 s	



Variant for direct current input 25A

The PLA33DL (DIN rail version) instrument variant is available also as a modification for direct AC current measurement up to 25 A. It is an ideal and compact solution for monitoring small loads without the need for current transformer installation.

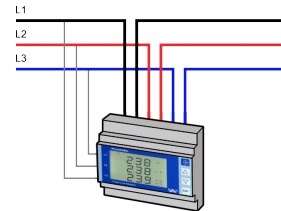

Flash memory for recorded parameters

Variants of the instruments PLA33CM and PLA33CMDL have 512MB flash memory for recording AVG values of up to 30 measured parameters. The memory recordings sampling period is user adjustable from 1 to 60 minutes as well as a list of parameters recorded into the memory.

Load profile memory

Analysers PLA33CM and PLA33CMDL have reserved space in their flash memory for recording load profiles. All six energy counters are recorded in a user defined period. Load profile recording is active for periods of 15, 30 and 60 minutes.

PLA33 variants

Type	RS485	I/O	Memory	Ins. RS485	25A input	Mounting
PLA33 L						panel
PLA33 C	•	•		○		panel
PLA33 CM	•	•	•	○		panel
PLA33DL L	•	•				DIN rail
PLA33DL C						DIN rail
PLA33DLCM		•	•	○		DIN rail
PLA33DLC25A	•	•		○	•	DIN rail
PLA33DLCM25A	•	•	•	○	•	DIN rail

Technical features

Supply voltage	230V _{AC} / 110V _{AC} (+10%, -15%) 24 V _{AC/DC}
System frequency	50 Hz / 60 Hz
Power consumption	max. 1.5 VA
Voltage measuring range L-N / L-L	10 ÷ 300 V _{AC} / 10 ÷ 520 V _{AC}
Current measuring range	10 mA ÷ 6 A
Frequency measuring range	40 ÷ 70 Hz
Clock uncertainty	< 1 s per day
Number of output/input	2 programmable
Output type	optical insulated transistor
Output maximum load	24 V _{DC} / 100 mA
Input type	optical insulated free potential
Input load capability	24 V _{DC} / 10 mA
Sampling frequency	6.4 kHz

Measuring transformer ratio of U and I	1 ÷ 1500
Communication interface	RS485
Communication protocol	Modbus RTU
RS485 communication speed	9.6 ÷ 57.6 kBd
Overvoltage class	600 V CAT III
Pollution degree	2
Working temperature	-25°C ÷ +60°C
Front panel dimensions	96 x 96 mm
Site depth	55 mm
Cutout dimensions	92 x 92 mm
Weight	620 g
IP rating	IP20 rear, IP54 front panel
Related standards	EN 61010-1, EN 60947-1, EN 61000-6-2, 2-4, 6-3

Variants codes of PLA analysers

PLA33

Instrument name	PLA33	C	M	DL	V24
RS485 communication interface					
L	light version without RS485 - simple monitor				
C	interface RS485				
IC	optically insulated RS485				
Flash memory					
-	without flash memory				
M	512MB flash memory				
Mounting					
-	panel mounting				
DL	DIN rail mounting				
DL25A	DIN rail with direct current measurement				
Supply voltage					
-	230 VAC supply voltage				
V100	100 VAC supply voltage				
V24	24 V AC/DC supply voltage				

PLA34

Instrument name	PLA34	RG	P
Current input			
-	standard version with CT xx/5A or xx/1A		
RG	Rogowski coils input		
Mounting			
-	panel version		
P	portable version (only for RG variant)		

PLA44RGP power quality analyser class A

The portable power quality analyser's design is based on the PLA44 power quality analyser. This portable variant is also following the panel version the standard EN 61000-4-30 class A for measuring power quality in LV and MV systems. Four voltage and current inputs allow PLA44RGP to be used in various applications. Current inputs made for Rogowski coils make connections to the measuring point quickly and easily.

A plastic suitcase with an IP rating IP54 and high mechanical endurance make the PLA44RGP tool able to take measurements in the harshest conditions of any kind of industry. An internal battery with a large capacity lets the PLA44RGP operate even with loss of power supply. The controlling board charges the battery automatically at presence of supply voltage.



- IT, TN, TT networks, 3 and 4-phase networks
- measurement of power quality according the EN 61000-4-30 class A
- continuous sampling of voltage and current inputs at 40 kHz
- 4 voltage measuring inputs and 4 current measuring inputs
- Fourier analysis from 1st to 65th harmonics of U_{L-N} , U_{L-L} , I , $P_{(+/-)}$ and $Q_{(L/C)}$
- harmonics, inter-harmonics of U_{L-N} , U_{L-L} , I according to EN 61000-4-7
- short term and long term flicker measurement according to the EN 61000-4-15
- detection of transients > 25 μ s
- detection of events > 10 ms
- measured data logger, event and transient memory 1GB flash
- communication interfaces Ethernet, USB
- universal auxiliary supply voltage input $85 \div 265 V_{AC/DC}$
- real-time clock backup for 10 years
- battery 3.5 Ah for full operation for up to 10 hours
- web-server and email notification for alarms and events

Measured parameters

PLA44RGP measures the same parameters with the same accuracy as the PLA44 power quality analyser. For exact values please refer to the table of measured parameters of the PLA44. By default the PLA44RGP does not measure temperature. Nevertheless the temperature sensor can be optionally delivered.

Internal memory

The portable power quality analyser PLA44RGP has 1 GB of internal non-volatile FLASH memory for recording measured parameters, events, transients and energy values. The memory is working in FIFO mode so when the memory is full, the oldest data is written over with the newest.

For an application when the 1 GB memory size is not enough, it is possible to request an instrument with a larger memory.

Technical features

Supply voltage	$85 \div 265 V_{AC/DC}$
System frequency	50 Hz / 60 Hz
Power consumption	max. 8 VA
Voltage measuring range L-N / L-L	$10 \div 600 V_{AC} / 18 \div 1000 V_{AC}$
Current measuring range	Rogowski coils
Frequency measuring range	$40 \div 70$ Hz
Clock uncertainty	< 1 s per day
Sampling frequency	40 kHz
Clock backup	10 years (Lithium battery)
Battery type	3.5 Ah (Li-On)
Battery operation time	10 hours
Display	5.7" TFT VGA (640x480px)
Rogowski coils current ranges	10 A, 30 A, 100 A, 300 A, 1 kA, 3 kA, 10 kA

* – Other length on the request ** – Larger memory on the request

Internal clock backup

The internal clock is synchronized via NTP servers if there is an Internet connection. The clock shift is less than 1 second per day to assure precise events and transients time flag recording. Inside the instrument is a Lithium battery for real time clock backup with a designed working life of 10 years.

Software tools

The operation of the instrument, measuring circuits adjustment and measured data analysis is performed by the software tool called Power Monitoring Software. Communication between the PLA44RGP and Power Monitoring Software is achieved via a USB or Ethernet connection.

Operation on battery

The portable power quality analyser PLA44RGP has an internal Li-On battery which is automatically charged when the instrument is connected to an energy source. When using a battery with a capacity of 3.5 Ah, the PLA44RGP can fully work for 10 hours including the TFT display operation.

Flexible current Rogowski coils

The portable analyser is delivered with four flexible Rogowski coils and an internal built-in digital integrator. The internal integrator allows the measurement of currents from 10 A to 10 kA with the same set of current measuring coils.

Standardly the Rogowski coils with a length of 40 cm are delivered with a PLA44RGP. Other lengths can be delivered if requested.

Rogowski coils length / diameter	40 cm / \varnothing 8 mm *
Rogowski coils test voltage	$7400 V_{RMS} / 1$ min
Communication interface	LAN, USB
Communication protocol	Modbus TCP, TCP/IP, FTP, HTTP, SMTP, NTP
Memory type / size	Flash / 1GB **
Overvoltage class	600 V CAT III
Pollution degree	2
Working temperature	$-30^{\circ}\text{C} \div +70^{\circ}\text{C}$
Dimensions	305 x 270 x 144 mm
Weight	7 kg
IP rating	IP54
Related standards	EN 61000-4-30, EN 61000-4-15, EN 61000-4-7

PLA404 power quality logger class S

A small but very powerful power quality logger with 4 voltage and 4 current inputs (Rogowski coils) for the use of measurement in IT, TN and TT networks. The PLA404 is an instrument designed for measurement according to the standard EN 61000-4-30 class S. The measured parameters list and accuracy classes are the same as for the PLA34 power quality analyser that is using the same hardware specification. The PLA404 is without a display and is designed for power quality measurements on site for further analysis according to the norm EN 50160.



- IT, TN, TT networks, 3 and 4-phase networks
- measurement of power quality according to the EN 61000-4-30 class S
- continuous sampling of voltage and current inputs at 40 kHz
- 4 voltage measuring inputs and 4 current measuring inputs
- Fourier analysis from 1st to 65th harmonics of U_{L-N} , U_{L-L} , I , $P_{(+/-)}$ and $Q_{(L/C)}$
- harmonics, inter-harmonics of U_{L-N} , U_{L-L} , I according to EN 61000-4-7
- short term and long term flicker measurement according to the EN 61000-4-15
- detection of transients > 25 μ s
- detection of events > 10 ms
- measured data logger, event and transient memory 1GB flash
- communication interfaces Ethernet, USB
- universal auxiliary supply voltage input $85 \div 460 V_{AC/DC}$
- real-time clock backup for 10 years
- web-server and email notification for alarms and events

Internal clock backup

The internal clock is synchronized via NTP servers if there is Internet connection. The clock shift is less than 1 second per day to assure precise events and transients time flag recording. Inside the instrument is a Lithium battery for real time clock backup with the designed working life of 10 years.

Measured parameters

The PLA404 measures the same parameters with the same accuracy as the PLA34 power quality analyser. Only one difference is that the PLA404 has four voltage measuring inputs and four current measuring inputs. For exact accuracy and range values please refer to the table of measured parameters for the PLA34.

Technical features

Supply voltage	$85 \div 460 V_{AC/DC}$
System frequency	50 Hz / 60 Hz
Power consumption	max. 4 VA
Voltage measuring range L-N / L-L	$10 \div 600 V_{AC} / 18 \div 1000 V_{AC}$
Current measuring range	Rogowski coils
Frequency measuring range	$40 \div 70$ Hz
Clock uncertainty	< 1 s per day
Sampling frequency	40 kHz
Clock backup	10 years (Lithium battery)
Rogowski coils current ranges	10 A, 30 A, 100 A, 300 A, 1 kA, 3 kA, 10 kA
Rogowski coils length / diameter	40 cm / \varnothing 8 mm

Internal memory

The portable power quality analyser PLA404 has 1 GB of internal non-volatile FLASH memory for recording measured parameters, events, transients and energy values. The memory works in FIFO mode so when the memory is full the oldest data is overwritten by the newest.

For an application when the 1 GB memory size is not enough, it is possible to request an instrument with a larger memory.

Software tools

The operation of the instrument, measuring circuits adjustment and measurement of data analysis is performed by the software tool called Power Monitoring Software. Communication between the PLA404 and Power Monitoring Software is achieved via a USB or Ethernet connection.

Flexible current Rogowski coils

The portable analyser is delivered with four flexible Rogowski coils and an internal built-in digital integrator. The internal integrator allows measurement of currents from 10 A to 10 kA with the same set of current measuring coils.

As a standard the Rogowski coils with a length of 40 cm are delivered with an PLA404. Other lengths can be delivered if requested.

Rogowski coils test voltage	$7400 V_{RMS} / 1$ min
Communication interface	LAN, USB
Communication protocol	Modbus TCP, TCP/IP, FTP, HTTP, SMTP, NTP
Overvoltage class	600 V CAT III
Pollution degree	2
Working temperature	$-30^{\circ}\text{C} \div +70^{\circ}\text{C}$
Dimensions	175 x 80 x 60 mm
Weight	700 g
IP rating	IP40
Related standards	EN 61000-4-30, EN 61000-4-15, EN 61000-4-7

Maximum demand controller HM2006

The controller is intended for power peak demand reduction of big consumers in an industrial area by disconnecting particular loads according to the trend of 15 minutes of consumption. HM2006 offers 5 inputs for energy meter pulses reading (+P, +Q, -P, -Q and synchronization pulse). One input can also be used for tariff indication. Via 6 changeover relay output contacts the mechanical contactor circuits of defined electrical loads are operated.

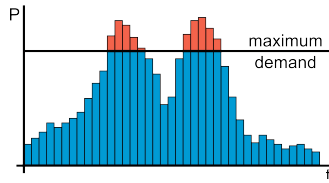

Internal load profile memory

In the HM2006 there is a built-in FIFO memory for load profile and outputs status with capacity for 40 days of recording. Once the memory is full, the newest data overwrites the oldest.

Internal synchronization pulse

The HM2006 has an internal real time clock with 48 hours backup. 1/4 period can be synchronized by an external signal or internal clock.

Operation principle

The HM2006 controller regulates demand according to a set maximal value of average hour demand in kW. This value is periodically compared with measured power demand during a quarter of an hour and, in the case of a fast power demand increase over the defined neutral zone, the controller disconnects appropriate loads.

If the power demand decreases under a certain level and power demand reserve appears, the controller starts to connect appropriate loads back to the system.

The device shows, during a quarter of an hour period, the calculation of the average hour power demand in kW according to the real power demand. After the incoming of the pulse for the new quarter-hour beginning, this value is erased. All disconnected loads will be connected back and a new regulation cycle will start.

The maximum reached quarter-hour value of power, the date and time of this event for every separate tariff are recorded into internal memory. Those maximal values are accessible through the device display. The history of every power demand curve during the quarter of an hour is saved to the internal memory with a capacity of 40 days of recording.

Internal power supply

The device is equipped with a metallically separated internal power supply of 12 VDC for supplying energy meter pulse outputs or the separation unit OP105.

Software tool

The HM2006 uses special software called HM2006PC for monitoring and configuration. The HM2006PC software is ready to be used with all type of BMR RS485 converters.

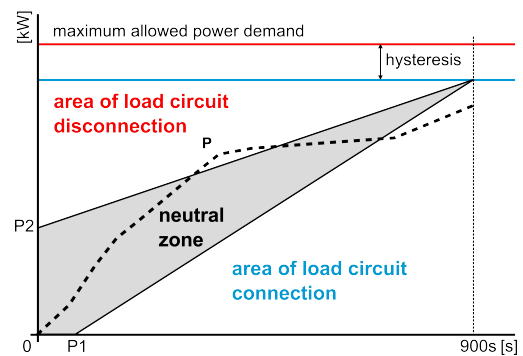

Schematic diagram

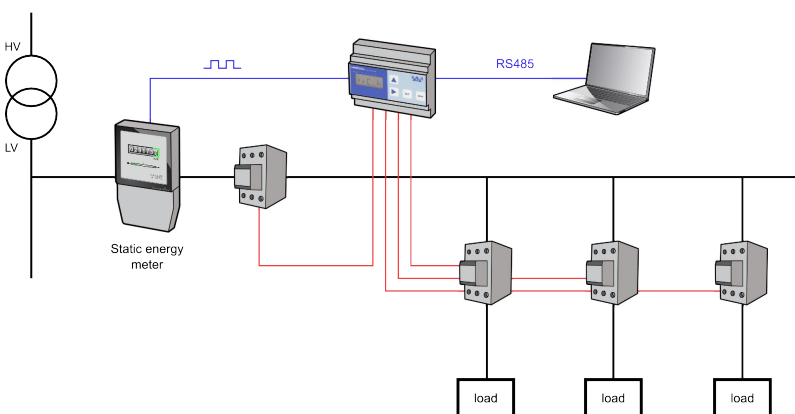

Technical features

Supply voltage	230 V _{AC} (+10%, -15%)
System frequency	50 / 60 Hz
Power consumption	< 1.5 VA
Number of pulse inputs	5 (+P, -P, +Q, -Q, synchr.)
Number of controlled outputs	6 changeover contacts
Switching power of relay outputs	3 A / 250 V _{AC}
Internal load profile memory	40 days (FIFO type)
Internal power supply	24 V _{DC}

Communication interface	RS485
Communication protocol	BMR
Real-time clock backup	48 hours
Working temperature	0°C + +70°C
Mounting	IEC 60715 (DIN 35 mm)
Dimensions	6 DIN rail modules
Weight	700 g
Protection degree	IP20

Accessories

As an optional accessory, BMR produces a range of communication converters for usage with BMR instruments equipped with an RS485 interface. Converters are used for various purposes of communication between an instrument and a PC.

For application with power, quality analysers PLA34 and PLA44 where there is no possibility of Internet connection for time synchronization via NTP servers there is a solution called NTS100. It is an NTP server unit synchronising the clock over the GPS satellites and provides the NTP service to the local network.

Converter type	USB485	WiFi485	LAN485	NTS100
Primary side	RS485	RS485	RS485	GPS
Secondary side	USB (USB 1.1)	WiFi	LAN	LAN
Baud rate	9.6 ... 115.2 kBd	9.6 ... 57.6 kBd	9.6 ... 57.6 kBd	10/100 Mbit/s
Output connector	USB type B	RP-SMA	RJ-45	RJ-45
Power supply	supplied from USB	230 V _{AC}	230 V _{AC}	230 V _{AC} (+10%/-15%)
Dimensions	102 x 53 x 30 mm	3 x DIN modules	3 x DIN modules	5 x DIN modules

Power Monitoring Software

This is a multi-thread software designed for remote control and management of BMR instruments equipped with a communication interface. PMS is prepared for installation on computers with operating systems MS Windows XP and newer.

PMS is based on server - client architecture where the server part takes care entirely of communication with all instruments and SQL database.

Automatic SQL backup

It is advanced SQL database management with the possibility to split existing databases for faster response. It allows adjustable periodical database splitting for speed optimization and best system response. Online and average data is recorded in the SQL database. Also data from instruments with an internal memory are downloaded to the SQL archives for off-line evaluation by the PMS evaluation program.

Communication protocols

This software supports various communication interfaces (USB, RS232, Ethernet) and protocols (Modbus TCP, Modbus RTU, Modbus RTU over TCP, FTP). Besides BMR converter support, the communication drivers are prepared to support a wide range of available converters.

EN 50160 reporting

Power Monitoring Software has a tool for making a report according to the EN 50160 norm from recordings stored in the SQL database. A report can be modified according to customer needs by modifying information such as the customer logo, company details and be performed over a user defined time interval.



Power Monitoring Software - online monitoring

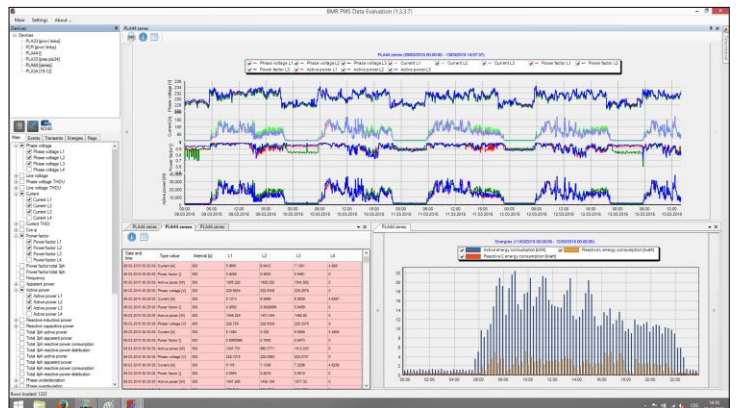

Power Monitoring Software - SQL data evaluation

Modular Instruments

It is a complete range of digital timers, monitoring and special relays designed with consideration of usage in the harshest conditions. Without any compromise in construction from the components point of view as well as a wide range of available functions assure reliability and long working life without any malfunctions. BMR modular instruments are relays that you can rely on.

Modular Instruments

Introduction

BMR produces a complete range of digital multifunction timers and monitoring relays. Devices are designed with attention focused on reliability, preciseness, measurement accuracy and a long working life. All produced relays are based on an industrial range of components and microprocessor technology, which assures the best operation accuracy.

Measured voltage and current are analysed by the DFT (Discreet Fourier Transformation), which separates disturbances, noise and high harmonics influence from the fundamental signal. Thanks to DFT, values for further calculation are more precise and the reaction is more accurate compared to the standard analogue relays.

Modular instruments are equipped with many features such as, for example, operating status and fault optical signalization. For fast installation all terminals are labelled so that the labels are visible in the mounting position. These features make installation and operation easier and help the user to identify possible network faults.

Range of modular devices

		Type	Description
Multifunction time relays		TRF10	time relay with 10 functions, 1 output and universal AC/DC supply voltage
		TRF10C	time relay with 10 functions, 2 outputs and universal AC/DC supply voltage
		TRF02A	time relay with 2 functions, 1 output and universal AC/DC supply voltage
		TRF02B	time relay with 2 functions, 1 output and universal AC/DC supply voltage
		TRF01	time relay with 1 function, 1 output and universal AC/DC supply voltage
		TRC01	asymmetric cycler relay with 2 functions, 1 output and universal AC/DC supply voltage
		TRS2D	time relay for delayed motor start by star / delta connection and 1 output
		TRF01L	time relay with 1 function for delayed release after supply voltage lost
Monitoring relays	Voltage	MRG3P	three-phase voltage monitoring relays for asymmetry, phase sequence, phase failure and min / max voltage
		MRG1P	three-phase or single-phase voltage monitoring relays for phase failure and min / max voltage control
		MRA3P	three-phase voltage monitoring relays for asymmetry, phase sequence and phase failure
	Current	MRI01T	AC/DC current monitoring relay with adjustable level in range of 0.1 ÷ 1 A and timer 0 ÷ 15 min
		MRI05T	AC/DC current monitoring relay with adjustable level in range of 0.5 ÷ 5 A and timer 0 ÷ 15 min
		MRI25T	AC current monitoring relay with adjustable level in range of 2.5 ÷ 25 A and timer 0 ÷ 15 min
	Others	MRF1P	frequency monitoring relay with adjustable max and min controlled frequency level
		MRL01	liquid level monitoring relay for conductive liquid control for min and max level control
		MTR01	thermistor monitoring relay for electrical motor overheating protection
	MTR02	thermistor monitoring relay for electrical motor overheating protection with galvanic insulation	
Thermostats	MSR01	sollar panel controller for hot water storage cylinder with immersion heater charging	
	DTR01	double thermostat with independent temperature measurements and settings	
	TR121	differential thermostat with 10 functions and 2 outputs	
Maximum current controllers	HJ10x	three-phase controller of maximum current of main circuit breaker with direct measurement	
	HJ30x	particular phase controller of maximum current of main circuit breaker with direct measurement	
	HJ110x	three-phase controller of maximum current of main circuit breaker with indirect measurement	
	HJ310x	particular phase controller of maximum current of main circuit breaker with indirect measurement	

Multiple-function time relays

Digital timers are produced with a wide range of available variants for domestic and industrial applications. All timers are equipped with universal supply voltage inputs.

- for switching of electric circuits up to 8 A depending on the set time, function and connection.
- adjustable time range: 0.1 s + 10 days
- control options: delayed operation, impulse after switching on, interval relay beginning with a pause/impulse, reaction to leading/trailing edge, reaction to connection/disconnection of supply voltage, reaction only to a control impulse edge,...
- universal supply voltage: 12 + 230 V_{AC}/12 + 220 V_{DC}
- time and function setting by knobs and change-over switches on the front panel of the device
- light indication at contacts closing (yellow LED)
- light indication of presence of supply voltage (green LED)
- each impulse led on input TL causes restart of timing depending on the set function
- in DC circuits the (+) conductor must be connected to terminal A1, and (-) to terminal A2

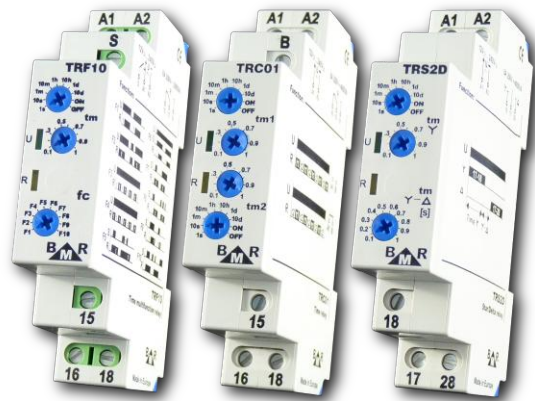

Range of timers

Device type	TRF10	TRF10C	TRF02A	TRF02B	TRF01	TRC01	TRS2D	TRF01L
Number of outputs	1	2	1	1	1	1	1	1
Number of functions	10	10	2	2	1	2	1	1
F1 - delay on operate	•	•	•	•				
F2 - interval	•	•						
F3 - flasher with pause start	•	•						
F4 - flasher with pulse start	•	•						
F5 - Off delay (S contact)	•	•	•		•			
F6 - On delay (S contact)	•	•		•				
F7 - single shot (S contact)	•	•						
F8 - single shot trailing edge (S)	•	•						
F9 - On / Off delay (S contact)	•	•						
F10 - latching relay (S contact)	•	•						
F11 - asymmetric cycler (pause start)						•		
F12 - asymmetric cycler (pulse start)						•		
F13 - delay motor start Y - Δ							•	
F14 - delay Off after supply voltage lost								•

Functions

F1 - delay on operate	F2 - interval	F3 - flasher with pause start
F4 - flasher with pulse start	F5 - Off delay (S contact)	F6 - On delay (S contact)

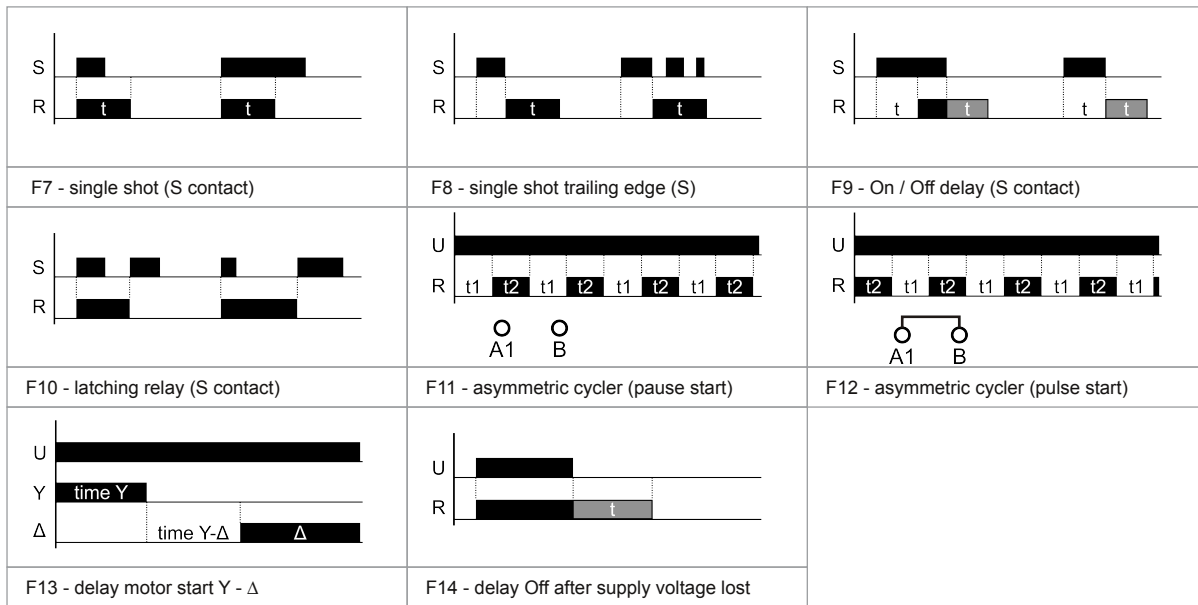

Terminals

- A – Time t1 setting
- B – Fine time t1 setting
- C – Function selection knob
- D – Time t2 setting
- E – Fine time t2 setting
- F – Start time for Y connection
- G – Reconnection Y – Δ delay

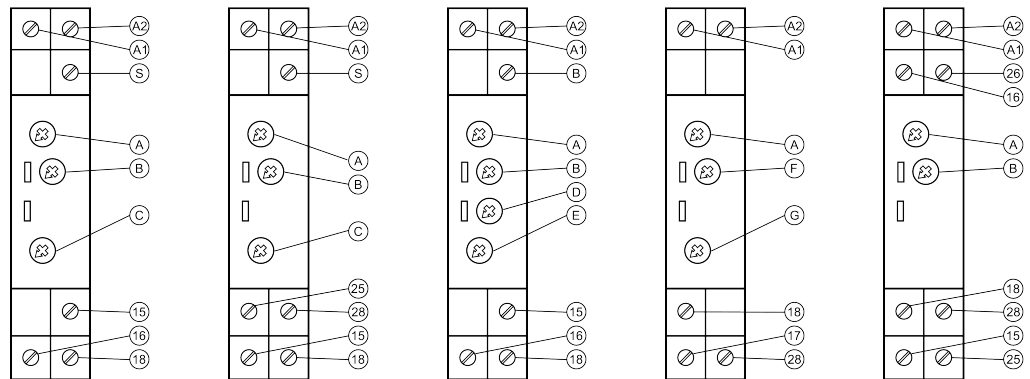

TRF10, TRF01,
TRF02A, TRF02B

TRF10C

TRC01

TRS2D

TRF01L

Diagrams

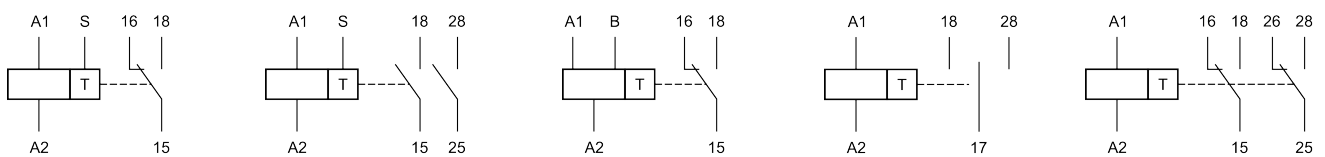

TRF10, TRF10C,
TRF01, TRF02A,
TRF02B

TRF10C

TRC01

TRS2D

TRF01L

Technical features

Supply voltage	12 ÷ 230 V _{AC/DC} (+10%, -15%)
System frequency	50 Hz / 60 Hz
Power consumption	< 1.5 VA / 1.2 W
Supply voltage indication	green LED
Closed contact indication	yellow LED
Time range	0.1 s ÷ 10 days
Rated operating voltage/current	250 V _{AC} / 8 A, 24 V _{DC} / 8 A
Max switched voltage	400 V _{AC} (5 A) / 150 V _{DC} (0,3A)
Max switched power	2000 VA / 192 W
Trigger current	15 A
Output mechanical lifetime	3 x 10 ⁶ cycles

Output electrical lifetime	1 x 10 ⁴ cycles (250 V _{AC} / 8 A)
Ambient temperature	-20°C ÷ +55°C
Storage temperature	-20°C ÷ +55°C
Working position	arbitrary
Mounting	IEC 60715 (DIN 35 mm)
IP rating	IP20
Electrical strength	4 kV
Conductor rigid and flexible	0.2 ÷ 2.5 mm ²
Weight	105 g (including packaging)
Dimensions	90 x 18 x 65 mm
Related standards	EN 61812-1, IEC 61010, IEC 61000

Voltage monitoring relays

Three-phase and single-phase voltage monitoring relays are designed for various usage in industrial and domestic applications. Voltage monitoring relays are equipped with visual fault diagnosis and have one output double-throw contact up to 8 A.

MRG3P

- overvoltage, undervoltage, phase failure, phase sequence, asymmetry monitoring

MRG1P

- overvoltage, undervoltage, phase failure monitoring
- three-phase or single-phase circuit usage

MRA3P

- phase failure, phase sequence, asymmetry monitoring



Functions

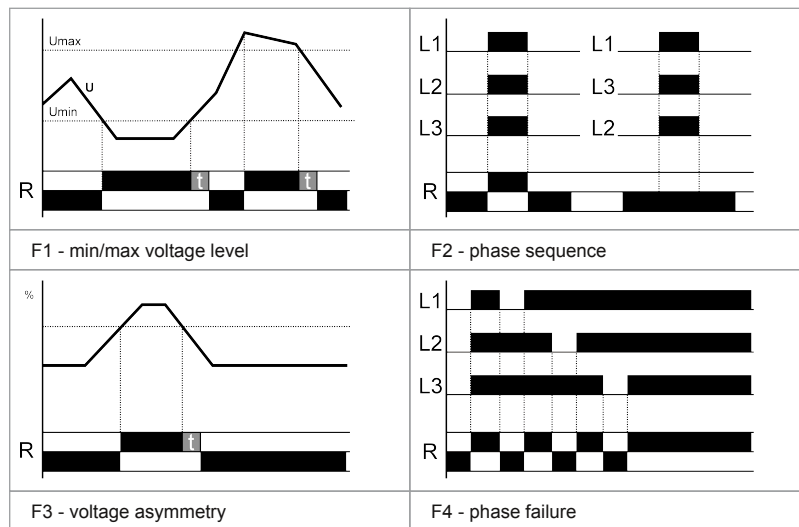

Terminals and diagram

A - Umax setting

B - Timer knob

C - Asymmetry knob

D - Umin setting

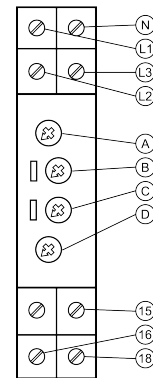
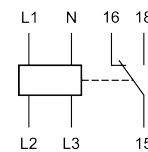

Range of voltage relays

Device type	Number of outputs	Number of monitoring functions	Monitoring functions				Single-phase application	Three-phase application
			F1 - min/max voltage level	F2 - phase sequence	F3 - voltage asymmetry	F4 - phase failure		
MRG3P	1	4	•	•	•	•		•
MRG1P	1	3	•			•	•	•
MRA3P	1	2		•	•	•		•

Signalization

AL - 1x			L1 failure - contact 15-16 closed
AL - 2x			L2 failure - contact 15-16 closed
AL - 3x			L3 failure - contact 15-16 closed
AL - OFF			No failure - contact 15-18 closed
AL - flash			Asymmetry failure: 15-16 closed
AL - ON			Phase sequence failure: 15-16 closed
U - ON			Presence of power supply
U - OFF			Power supply is not present

Technical features

Supply voltage	230 V _{AC} (+20%, -30%), 50/60Hz
Power consumption	max. 1.5 VA
Minimum controlled voltage (UL-N)	180 ÷ 220 V _{AC} , Off
Maximum controlled voltage (UL-N)	225 ÷ 265 V _{AC} , Off
Asymmetry	5 ÷ 20%
Adjustable delay	0 ÷ 10 s
Supply voltage indication	green LED
Failure indication	red LED
Rated operating voltage/current	250 V _{AC} / 8 A
Max switched voltage	400 V _{AC}
Max switched power	2000 VA
Trigger current	15 A

Hysteresis	fix 5%
Output mechanical endurance	3 x 10 ⁶ cycles
Output electrical endurance	1 x 10 ⁴ cycles (250 V _{AC} / 8 A)
Ambient temperature	-20°C ÷ +55°C
Working position	arbitrary
Mounting	IEC 60715 (DIN 35 mm)
IP rating	IP20
Electrical strength	4 kV
Conductor rigid and flexible	0.2 ÷ 2.5 mm ²
Weight	75 g
Dimensions	90 x 18 x 65 mm
Related standards	IEC 60255, IEC 61010, IEC 61000

Current monitoring relays MRI01T/05T/25T

This range of current monitoring relays are used for the control of AC and DC current signal in various industrial and domestic applications. The measuring part of the instrument is metallically separated from the current connection terminals. The monitoring relays MRI range have one double-throw output contact up to 8 A.

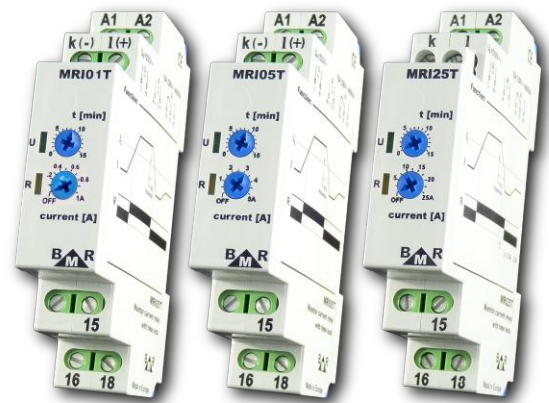

MRI01T

- monitoring of DC and AC current
- measuring current range from 0.1 A to 1 A

MRI05T

- monitoring of DC and AC current
- measuring current range from 0.5 A to 5 A

MRI25T

- monitoring of AC current
- measuring current range from 2.5 A to 25 A

Functions

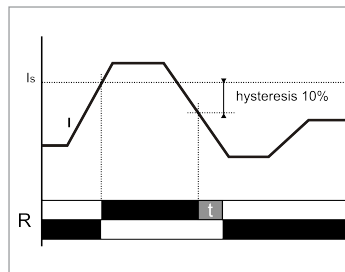

If the set current level is exceeded, output relay will make a connection. If the measured current level goes under the set level minus a fix hysteresis of 10%, output relay will disconnect. Hysteresis reduces relay bouncing at the threshold limit of current values. The OFF position disables current measurement, output is closed and the yellow LED is off. Contact no. 16 – 15 is closed.

Range of current relays

Device type	Number of outputs	Current measuring range	AC current	DC current
MRI01T	1	0.1 ÷ 1 A	•	•
MRI05T	1	0.5 ÷ 5 A	•	•
MRI25T	1	2.5 ÷ 25 A	•	

Signalization

U - ON		Presence of power supply
U - OFF		Supply voltage not present or incorrect polarity
R - ON		Current > Is – contact: 15 - 18 closed
R - OFF		Current < Is – contact: 15 - 16 closed

Terminals and diagram

A1 - L1 or +

A2 - N or -

A - Timer knob

B - Current Is setting

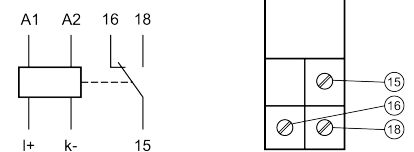

Technical features

Supply voltage	230 V _{AC} (+10%, -15%), 50/60Hz
Supply voltage terminals	L (A1), N (A2)
Power consumption	max. 1.5 VA
Measuring current terminals	k (-), I (+)
Measuring current range MRI01T	0.1 ÷ 1 A _{AC/DC}
Max. input current MRI01T	2 A
Measuring current range MRI05T	0.5 ÷ 5 A _{AC/DC}
Max. input current MRI05T	7 A
Measuring current range MRI25T	2.5 ÷ 25 A _{AC}
Max. input current MRI25T	32 A
Hysteresis	fix 10%
Number and type of output contact	1 x changeover
Rated operating voltage/current	250 V _{AC} / 8 A
Max switched voltage	400 V _{AC}

Max switched power	2000 VA
Trigger current	15 A
Mechanical lifetime	3 x 10 ⁶ cycles
Electrical endurance	1 x 10 ⁴ cycles (250 V _{AC} / 8 A)
Ambient temperature	-20°C ÷ +55°C
Storage temperature	-40°C ÷ +70°C
Working position	arbitrary
Mounting	IEC 60715 (DIN 35 mm)
IP rating	IP20
Electrical strength	4 kV
Conductor rigid and flexible	0.2 ÷ 2.5 mm ²
Weight	75 g
Dimensions	90 x 18 x 65 mm
Related standards	IEC 60255, IEC 61010, IEC 61000

Frequency monitoring relay MRF1P

The MRF1P is monitoring relay designed for network frequency control with adjustable maximum and minimum zone levels.

The frequency monitoring relay is equipped with an internal timer for adjustable delay during the reaction and reconnection.

The relay MRF1P is equipped with one output double-throw contact up to 5 A.

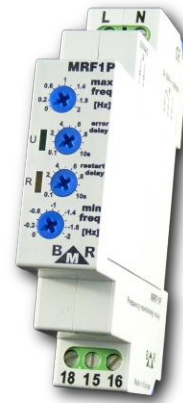

Functions

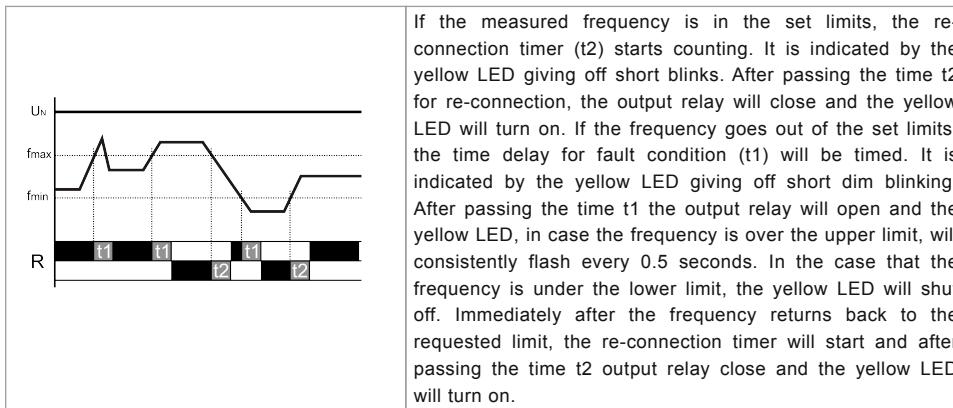

Signalization

U - ON		Presence of power supply
U - OFF		Power supply is not present
R - ON		Frequency in set limits – contact: 15-18 closed
R - OFF		Frequency under fmin – contact: 15-16 closed
R - 0.5 s		Frequency over fmax – contact: 15-16 closed
R - short OFF		Failure timer t1 is active
R - short ON		Repeating start timer t2 is active

Terminals and diagram

- A – Maximum frequency
- B – Error delay t1
- C – Restart delay t2
- D – Minimum frequency

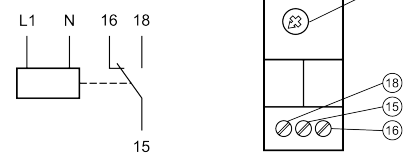

Technical features

Supply voltage	230 V _{AC} (+10%, -15%)
Supply voltage terminals	L, N
Power consumption	max. 1.5 VA
Measuring frequency range	40 ÷ 70 Hz
Hysteresis	fix 0.2 Hz
Measuring cycle	200 ms
Frequency control limits (adjustable)	±2 Hz (0 disables function)
Fault condition time (adjustable)	0.1 ÷ 10 s
Re-connection delay time	0.1 ÷ 10 s
Supply voltage indication	green LED
Output indication	yellow LED
Number and type of output contact	1 x changeover
Rated operating voltage/current	250 V _{AC} / 5 A
Max. switched voltage	400 V _{AC}

Trigger current	10 A
Max. switched power	1000 VA
Mechanical endurance	3 x 10 ⁶ cycles
Electrical endurance	1 x 10 ⁴ cycles (250 V _{AC} / 5 A)
Ambient temperature	-20°C ÷ +55°C
Storage temperature	-40°C ÷ +70°C
Working position	arbitrary
Mounting	IEC 60715 (DIN 35 mm)
IP rating	IP20
Electrical strength	4 kV
Conductor rigid and flexible	0.2 ÷ 2.5 mm ²
Weight	75 g
Dimensions	90 x 18 x 65 mm
Related standards	IEC 60255, IEC 61010, IEC 61000

Motor thermistor monitoring relay MTR01

The MTR01 relay controls the temperature of electrical motor windings. Temperature monitoring is based on the measurement of the PTC thermistor which is built inside the electrical motor windings. For protection purposes, the monitoring relay also controls any possible short-circuits of the connection cable and thermistor probe disconnection. The relay has one output double-throw contact up to 8 A.

The MTR01V24 type is designed for the supply voltage of 24 V_{AC/DC}. Other parameters and features are the same as for the MTR01.

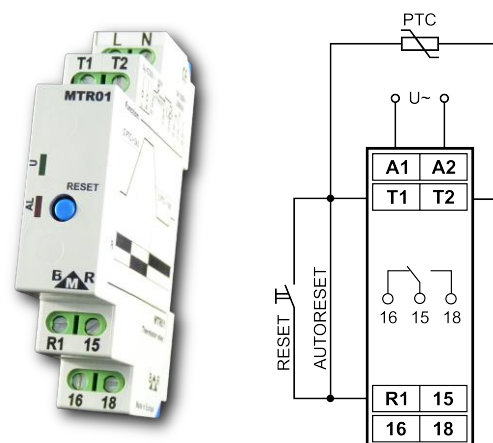

Functions

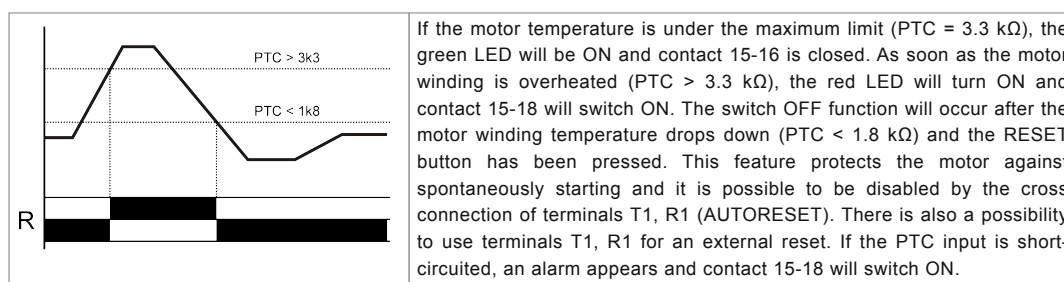

Signalization

U – ON		Presence of power supply
U – OFF		Power supply is not present
AL – ON		Motor temperature is over the set limit or temperature probe is disconnected.
AL – OFF		Motor temperature is under set limit
AL – flashing		Short circuit at the PTC input (PTC < 50Ω)

Terminals and diagram

A – Reset button

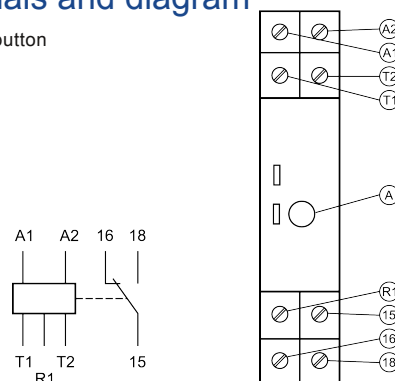

Technical features

Supply voltage MTR01	230 V _{AC} (+10%, -15%), 50/60Hz	Trigger current	15 A
Supply voltage MTR01V24	24 V _{AC/DC}	Max. switched voltage	400 V _{AC}
Power consumption	max. 1.5 VA	Mechanical lifetime	3 x 10 ⁶
Measuring terminals	T1, T2	Electrical lifetime	1 x 10 ⁴ (250 V _{AC} , 8 A)
Supply voltage terminals	A1, A2	Ambient temperature	-20°C ÷ +55°C
Thermistor operating state	50 Ω < PTC < 3.3 kΩ	Storage temperature	-40°C ÷ +70°C
Thermistor ALARM state	PTC > 3.3 kΩ or PTC < 50 Ω	Working position	arbitrary
Condition of ALARM status cancelling	PTC < 1.8 kΩ + button RESET (AUTORESET)	Mounting	IEC 60715 (DIN 35 mm)
Supply voltage indication	green LED	IP rating	IP20
Alarm status indication	red LED	Electrical strength	4 kV
Number and type of output contact	1 x changeover	Conductor rigid and flexible	0.2 ÷ 2.5 mm ²
Rated operated voltage / current	250 V / 8 A	Weight	75 g
Max. switched power	2000 VA	Dimensions	90 x 18 x 65 mm
		Standards	IEC 60255, IEC 61010, IEC 61000

Liquid level monitoring relay MRL01

The MRL01 is a double function level relay designed to control the maximal and minimal level of conductive liquid in the vessel.

The relay can be used to pump liquid up (function UP) or to pump liquid down (function DOWN). In the case that the vessel is made from conductive material, it can be used instead of a GND probe.

The relay uses an AC current for measurement which avoids electrolysis and probe oxidation. The relay has one double-throw output contact up to 16 A.

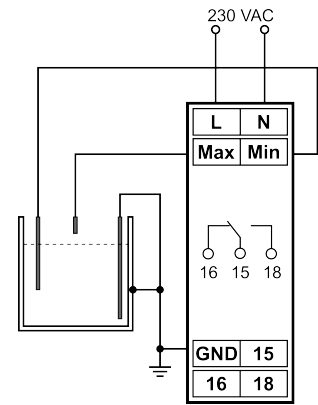
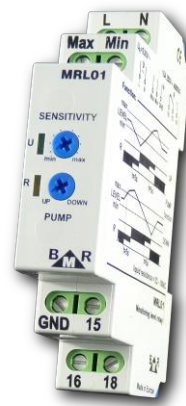

Functions

<p>Tank filling</p>	<p>Tank draining</p>	<p>PUMP UP - If the level decreases below the minimal limit and remains that way for the time of at least 2 s, the relay will start the pump up process. In the moment after the maximal limit has been exceeded for more than 2 s, the relay will stop the pump up process.</p> <p>PUMP DOWN - If the level exceeds the maximum limit and remains that way for the time of 2 s at least 2 s, the relay will start the pump down process. In the moment after the minimal limit has been exceeded for more than 2 s, the relay will stop the pump down process.</p>
---------------------	----------------------	---

Signalization

U – ON		Presence of power supply
U – OFF		Power supply is not present
R – ON		Contact no. 15-18 is closed
R – flashing		Signal noise ratio is lower than sensitivity

Terminals and diagram

A – Sensitivity setting
B – Function selection

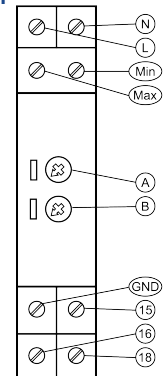
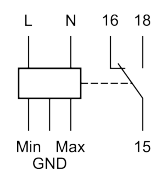

Technical features

Supply voltage	230 V _{AC} (+10%, -15%), 50/60Hz
Power consumption	max. 1.5 VA
Supply voltage indication	green LED
Output indication	yellow LED
Sensitivity setting	5 kΩ ÷ 100 kΩ
Terminal for Min / Max level	Min / Max
Common measuring terminal	GND
Liquid fluctuation elimination delay	2 s
Number and type of output contact	1 x changeover
Rated operated voltage / current	250 V / 16 A
Max. switched power	4000 VA
Trigger current	30 A

Max. switched voltage	400 V _{AC}
Mechanical lifetime	3 x 10 ⁶ cycles
Electrical lifetime	1 x 10 ⁴ (250 V _{AC} , 16 A)
Ambient temperature	-20°C ÷ +55°C
Working position	arbitrary
Mounting	IEC 60715 (DIN 35 mm)
IP rating	IP20
Electrical strength	4 kV
Conductor rigid and flexible	0.2 ÷ 2.5 mm ²
Weight	75 g
Dimensions	90 x 18 x 65 mm
Related standards	IEC 60255, IEC 61010, IEC 61000

Multifunction differential relay TR121

The TR121 is a multifunctional differential thermostat with 6 operation functions and 4 service functions.

The relay has two NO output contacts up to 16 A.

The multifunction differential thermostat TR121 is delivered together with two sensors with cable lengths of 3 meters.

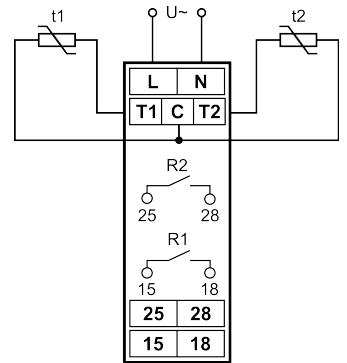
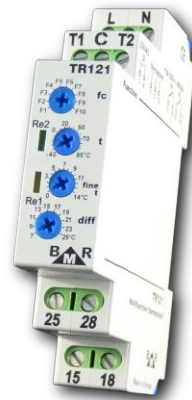

Functions

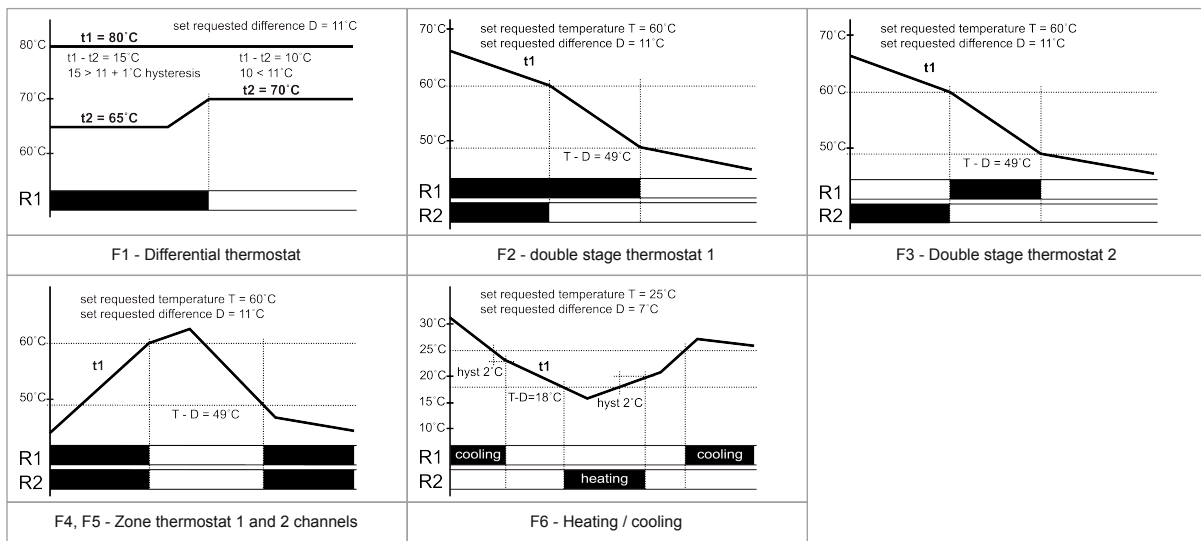

Signalization

Re2 - flashing			Presence of supply voltage, outputs are off
Re1 - ON			Output relay Re1 is connected
Re2 - ON			Output relay Re2 is connected
Re1 - flashing			Failure of one of temperature sensor
Re2 - flashing			

Terminal description

- A – Function selection knob
- B – Temperature setting knob
- C – Fine temperature setting
- D – Difference setting knob

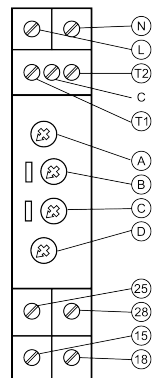
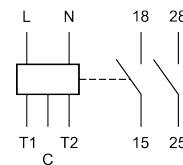

Technical features

Supply voltage	230 V _{AC} (+10%, -15%), 50/60Hz
Power consumption	max. 1.5 VA
Supply voltage indication	green LED
Output indication	yellow LED
Number of functions	6 + 4
Temperature sensor	BMR RT_P (NTC 3k3)
Measuring temperature range	-25°C ÷ +95°C
Number and type of output contact	2 x changeover
Rated operated voltage / current	250 V / 16 A
Max. switched power	4000 VA
Trigger current	30 A
Max. switched voltage	400 V _{AC}

Mechanical lifetime	3 x 10 ⁶ cycles
Electrical lifetime	1 x 10 ⁴ (250 V _{AC} , 8 A)
Ambient temperature	-20°C ÷ +55°C
Storage temperature	-40°C ÷ +70°C
Working position	arbitrary
Mounting	IEC 60715 (DIN 35 mm)
IP rating	IP20
Electrical strength	4 kV
Conductor rigid and flexible	0.2 ÷ 2.5 mm ²
Weight	75 g
Dimensions	90 x 18 x 65 mm
Related standards	IEC 60255, IEC 61010, IEC 61000

Double thermostat DTR01

The DTR01 independently keeps a set reference temperature with hysteresis 2°C set reference temperature with hysteresis 2°C for both channels.

The relay has two NO output contacts up to 16 A.

The double thermostat DTR01 is supplied together with two NTC 3k3 sensors with 3 meter long cable lengths.

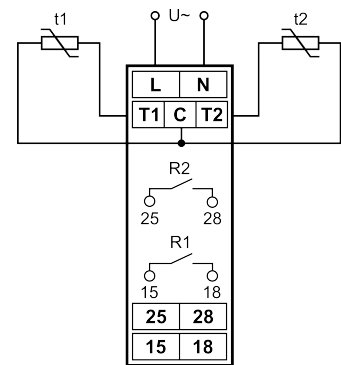
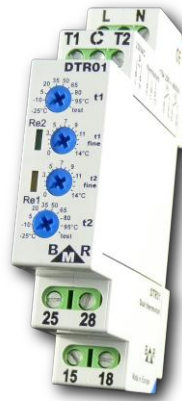

Functions

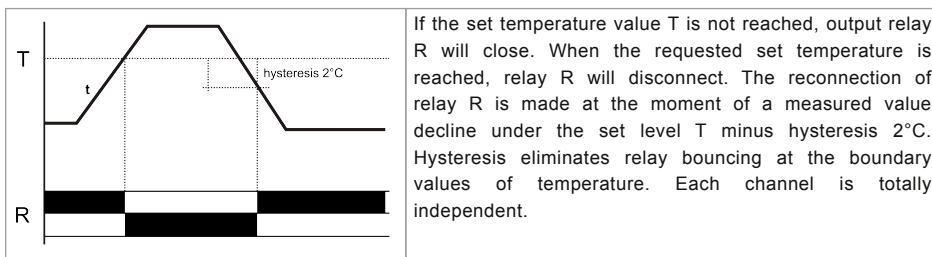

Signalization

Re2 - flashing		Presence of power supply
Re1 - ON		Power supply is not present
Re2 - ON		Contact no. 15-18 is closed
Re1 - flashing		Signal noise ratio is lower than sensitivity. Sensitivity has to be reduced by rotary button.
Re2 - flashing		

Terminal description

- A – Function selection knob
- B – Temperature setting knob
- C – Fine temperature setting
- D – Difference setting knob

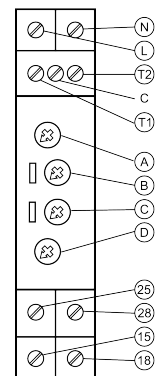
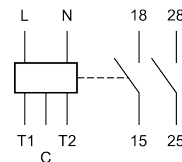

Technical features

Supply voltage	230 V _{AC} (+10%, -15%), 50/60Hz
Power consumption	max. 1.5 VA
Supply voltage indication	green LED
Output indication	yellow LED
Number of functions	1
Temperature sensor	BMR RT_P (NTC 3k3)
Measuring temperature range	-25°C ÷ +95°C
Number and type of output contact	2 x changeover
Rated operated voltage / current	250 V / 16 A
Max. switched power	4000 VA
Trigger current	30 A
Max. switched voltage	400 V _{AC}

Mechanical lifetime	3 x 10 ⁶ cycles
Electrical lifetime	1 x 10 ⁴ cycles (250 V _{AC} , 8 A)
Ambient temperature	-20°C ÷ +55°C
Storage temperature	-40°C ÷ +70°C
Working position	arbitrary
Mounting	IEC 60715 (DIN 35 mm)
IP rating	IP20
Electrical strength	4 kV
Conductor rigid and flexible	0.2 ÷ 2.5 mm ²
Weight	75 g
Dimensions	90 x 18 x 65 mm
Related standards	IEC 60255, IEC 61010, IEC 61000

Solar panel heating controller MSR01

The controller MSR01 is designed for controlling the storage cylinder heating with an immersion heater and solar panel support charging. The MSR01 controls storage cylinder charging according to the actual temperature in the solar panel and according to the requested temperature in the storage cylinder. The electrical charging process can be blocked by a centralized telecontrol signal.

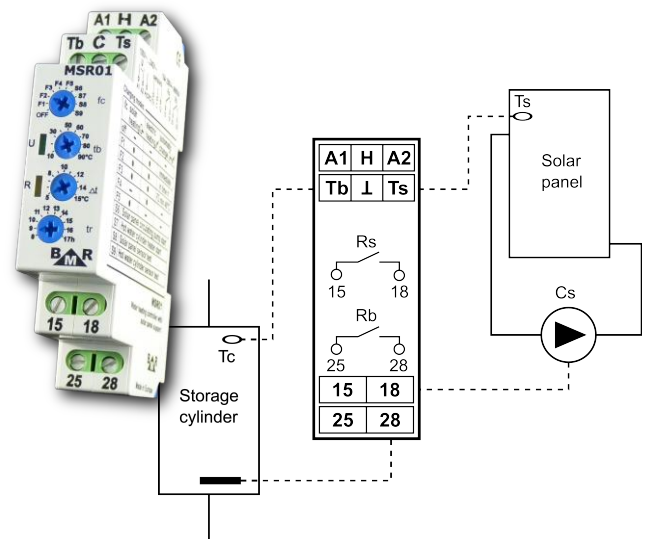

Functions

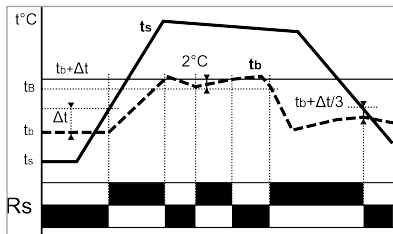

- F1 – cylinder charging by solar panel and electrical energy. Heating is automatically switched between the solar panel and electrical energy.
- F2 – cylinder charging by solar panel and electrical energy. It is expected that after cylinder discharging, solar panel heating will be available and will wait for this for set time t_r . Automatic charging with solar panel is priority.
- F3 – cylinder charging by solar panel and electrical energy. After cylinder is discharged, relay waits for time t_r on solar panel heating. Automatic charging with the solar panel has priority with ensured minimum water heating in cylinder to a temperature of 40°C . Setting of requested temperature t_b (cylinder temperature) has to be higher than 40°C .
- F4 – cylinder charging by electrical energy only
- F5 – cylinder charging by solar panel only
- S6 – S9 service functions

Adjustable parameters

t_b	Setting of requested temperature in storage cylinder
Δt	The temperature difference between solar panel temperature and cylinder temperature. The solar panel has to have a higher set temperature value than the cylinder, otherwise it is considered that solar panel is not supplying the needed caloric supply and the MSR01 will begin charging with the immersion heater.
t_r	Recharging time is a time delay when it is expected that solar panel will start the caloric supply again. If the solar panel does not start within this time then the cylinder will begin charging with the immersion heater.

Terminal description

- A – Function selection
- B – Storage cylinder temperature
- C – Solar panel-storage cylinder difference
- D – Electric charge delay setting

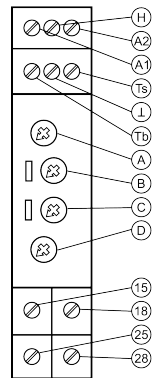
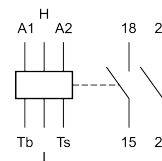

Technical features

Supply voltage	$100 \div 230 V_{AC}$
Power consumption	max. 1.5 VA
Supply voltage indication	green LED
Output indication	yellow LED
Storage cylinder temperature setting	$10 \div 90^\circ\text{C}$
Temperature difference setting	$5 \div 15^\circ\text{C}$
Delay for immersion heater start	off, 8 ÷ 17 hours
Number and type of output contact	2 x NO
Rated operated voltage / current	250 V / 16 A
Max. switched power	4000 VA
Trigger current	30 A
Max. switched voltage	$400 V_{AC}$

Mechanical lifetime	3×10^6 cycles
Electrical lifetime	1×10^4 ($250 V_{AC}$, 8 A)
Ambient temperature	$-20^\circ\text{C} \div +55^\circ\text{C}$
Storage temperature	$-40^\circ\text{C} \div +70^\circ\text{C}$
Mounting position	arbitrary
Mounting	IEC 60715 (DIN 35 mm)
IP rating	IP20
Electrical strength	4 kV
Conductor rigid and flexible	$0.2 \div 2.5 \text{ mm}^2$
Weight	75 g
Dimensions	90 x 18 x 65 mm
Related standards	IEC 60255, IEC 61010, IEC 61000

MCB maximum current controller HJ

The current in all three phases is digitalized and from measured values calculated by the DFT effective current value. If this value is higher than the value set by the DIP switch, measurement is repeated in 200 ms and if this calculated value is also higher than the set value, stage No. 1 will be disconnected. During the next measurement, the fall of the current after stage No. 1 disconnection is saved. If the value of the measured current is still higher than the set value, then after 3 seconds stage No. 2 will be disconnected too and the fall of current is saved.

Reconnection of appropriate stage is achieved in the case that the measured current value minus the fall of the current of the stage increased by 1 A is less than set current maximum.

During checking, if more than one stage was disconnected, preference is given to the first disconnected stage. In the case that the above mentioned condition is not valid for this stage, another stage in the sequence will be checked.

This operation procedure eliminates the controller reaction to short circuits and current transient events which are present, for example, during the motor start-up. The applied measuring method also assures perfect accuracy for currents with distortion and a non-sinusoidal wave.



Device variants

Type	Output number	Current measurement	Current level setting	Current level setting
HJ101	1	direct < 100 A	in step of 1 A	Device controls maximum current at every phase independently. Based on the exceeded current at any phase, the device reduces power in all three phases together. Suitable for three-phase electrical appliances control.
HJ102	2	direct < 100 A	in step of 1 A	
HJ103	3	direct < 100 A	in step of 1 A	
HJ111	1	indirect via CT ..5A	in step of 4 A	
HJ112	2	indirect via CT ..5A	in step of 4 A	
HJ113	3	indirect via CT ..5A	in step of 4 A	
HJ303	1 per phase	direct < 100 A	in step of 1 A	Device controls maximum current at every phase independently. Based on exceeded current at particular phase device reduces power just in this phase. Suitable for single-phase electrical appliances control.
HJ306	2 per phase	direct < 100 A	in step of 1 A	
HJ313	1 per phase	indirect via CT ..5A	in step of 4 A	
HJ316	2 per phase	indirect via CT ..5A	in step of 4 A	

Schematic connection

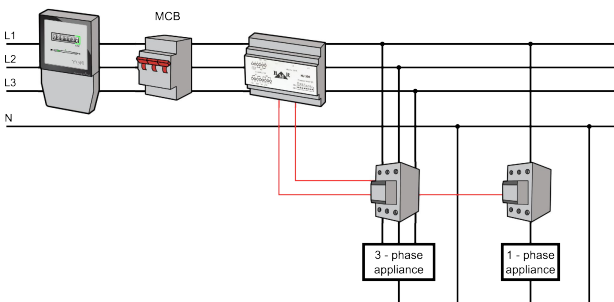

HJ10x connection

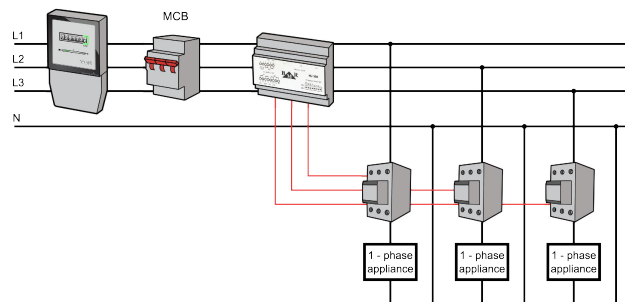

HJ30x connection

Technical features

Supply voltage	230 V _{AC} (+10%, -15%)
System frequency	50/60 Hz
Power consumption	1.5 VA
Direct current measurement range	3 x 100 A
Indirect current measurement range	3 x 5 A
Number and type of output contact	1 ÷ 6 NC
Switching power	250 V _{AC} / 5 A

Mechanical lifetime	3 x 10 ⁶ cycles
Electrical lifetime	1 x 10 ⁴ cycles (250 V _{AC} , 5 A)
Ambient temperature	0°C ... +70°C
Mounting	IEC 60715 (DIN 35 mm)
IP rating	IP20
Weight	0.5 kg
Dimensions	6 DIN rail modules

