

VLT® 2800 / 5000 / 5000 FLUX / FCD 300

Instruction

Brake Resistor



**■ Contents**

<b>Introduction</b> .....	2
Description of the brake system .....	2
<b>Examples</b> .....	3
Example 1 - Conveyor belt .....	3
Example 2 - Centrifuge .....	5
<b>Calculation of the brake resistor</b> .....	6
Brake setup .....	6
Calculation of brake resistor values .....	6
Calculation of braking power .....	7
Calculation of the brake resistor peak power .....	7
Calculation of the brake resistor average power .....	8
<b>Braking</b> .....	9
Braking of inertia .....	9
Continuous braking .....	9
D.C. injection braking .....	9
AC-braking VLT 2800 and FCD 300 .....	9
Optimum braking .....	9
Brake cable .....	10
Protective functions during installation .....	10
Description of VLT 5000 brake .....	11
<b>Programming</b> .....	12
VLT 5000 Process parameters .....	12
VLT 5000 FLUX parameters .....	12
VLT 2800 parameters .....	13
FCD 300 parameters .....	13
<b>Brake resistor overview</b> .....	14
Brake resistor for VLT 5001-5500 10% duty-cycle data and codenumber .....	14
Brake resistor for VLT 5001-5102 40% duty-cycle data and codenumber .....	16
Brake resistor for VLT 2803-2882 duty-cycle 40% data and codenumber .....	17
Brake resistor for VLT FCD 303-335 duty-cycle 40% data and codenumber .....	17
Brake resistor for VLT 5001-5500 10% duty-cycle cablegland, weight and drawing no. ....	19
Brake resistor for VLT 5001-5102 40% duty-cycle cablegland, weight and drawing no. ....	20
Brake resistor for VLT 2803-2882 40% duty-cycle cablegland, weight and drawing no. ....	21
Brake resistor for VLT FCD 303-335 40% duty-cycle cablegland, weight and drawing no. ....	21
<b>Drawings 1 - 19</b> .....	22

Danfoss offers a range of brake resistors for frequency converters, types 2800, 5000, 5000 FLUX and FCD 300.

#### ■ Description of the brake system

When the speed reference of a frequency converter is reduced, the motor acts as a generator and brakes. When a motor acts as a generator, it supplies energy to the frequency converter which is collected in the intermediate circuit. The function of the brake resistor is to provide a load on the intermediate circuit during braking, thereby ensuring that the braking power is absorbed by the brake resistor.

If a brake resistor was not used, the intermediate circuit voltage of the frequency converter would continue to increase, until it cuts out for protection. The advantage of using a brake resistor is it enables braking of a heavy load quickly, e.g. on a conveyor belt.

Danfoss has chosen a solution in which the brake resistor does not form an integral part of the frequency converter.

This offers the user the following advantages:

- The resistor time cycle can be selected as required
- The heat developed during braking can be conveyed beyond the panel cabinet to allow the energy to be used
- There is no overheating of the electronic components, even if the brake resistor is overloaded

---

#### ■ Knowledge of the system

If the right brake resistor is to be selected, it is necessary to know how often and by how much the motors are to brake.

In the following, some examples are given of calculations of the required braking for a conveyor belt and a centrifuge, respectively.

---

■ Example 1 - Conveyor belt

Fig. 1 shows the relation between the braking power and the acceleration/braking of a conveyor belt. As can be seen, the motor power during braking is negative, since the torque on the motor shaft is negative. The braking power, i.e. the power to be dissipated to the brake resistor, corresponds almost to the negative motor power, taking the losses in the motor and the frequency converter into account. The example also shows that the motor power is time-dependent.

Kinetic energy (E) in conveyor belt + motor:

$$E = 0.5 \times m \times v^2 + 0.5 \times j \times \omega^2 \text{ [Ws]}$$

m = mass with linear movement [kg]

v = speed of mass with linear movement [m/s]

j = inertia of motor and gear box (kgm<sup>2</sup>)

$$\omega = \text{motor speed} = \frac{n \times 2\pi}{60} \text{ [rad/s]}$$

This formula may also be expressed as follows:

$$E = 0.5 \times m \times v^2 + 0.0055 \times j \times n^2 \text{ [Ws]}$$

However, not all of the energy is to be dissipated to the brake resistor. The friction of the conveyor belt and the power loss of the motor also contribute to the braking function. Consequently, the formula for energy dissipation (E<sub>b</sub>) to the brake resistor is as follows:

$$E_b = (0.5 \times m \times v^2 + 0.5 \times j \times \omega^2 - 0.5 \times M_f \times \omega) \times \eta_{\text{motor}} \text{ [Ws]}$$

M<sub>f</sub> = Friction torque [Nm]

η<sub>M</sub> = Motor efficiency

When:

$$\omega = \frac{n \times 2\pi}{60}$$

is inserted, the result is as follows:

$$E_b = (0.5 \times m \times v^2 + 0.0055 \times j \times n^2 - 0.052 \times n \times M_f) \times \eta_M \text{ [Ws]}$$

■ Fig. 1

The relation between braking power and acceleration/braking of a conveyor belt.

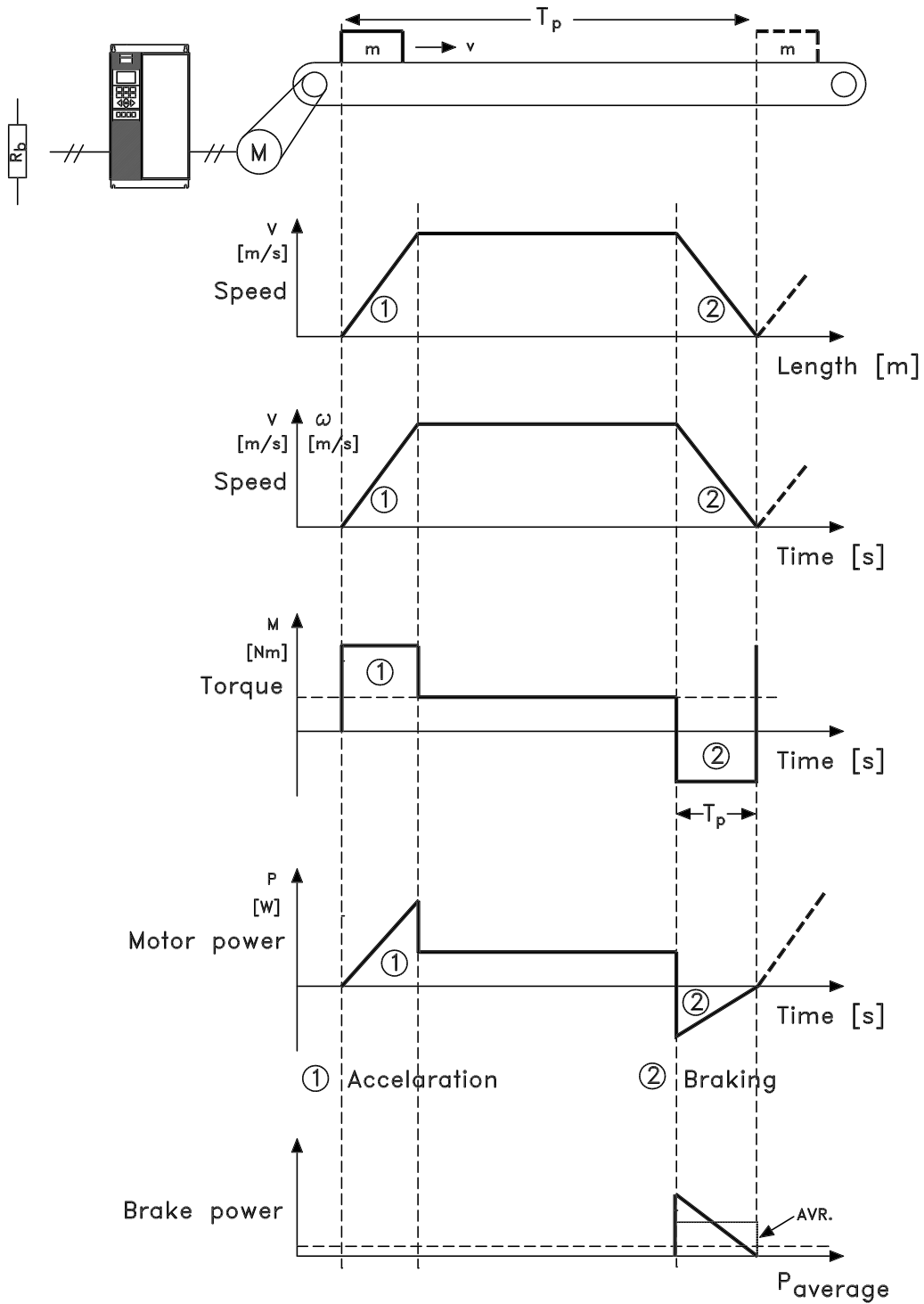

175ZA397.11

■ Example 2 - Centrifuge

Another typical application in which braking can be required on centrifuges. The weight of the centrifuge content is m.

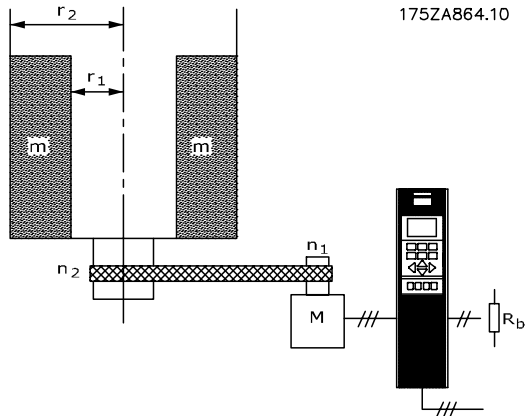

- $j_c =$  centrifuge inertia =  $\frac{1}{2} \times m \times (r_1^2 + r_2^2)$  [kgm<sup>2</sup>]
- $j_M =$  Gear motor inertia [kgm<sup>2</sup>]
- $\eta_M =$  Gear motor efficiency
- $n_1 =$  max. motor speed [rpm]
- $n_2 =$  max. centrifuge speed [rpm]

$$E_b = (0.0055 \times j_c \times n_2^2 + 0.0055 \times j_M \times n_1^2) \times \eta_M \text{ [Ws]}$$

Examples

■ Brake setup

Fig. 2 shows a brake set-up using a frequency converter.

The following sections use expressions and abbreviations with respect to a brake set-up that can be seen from fig. 2.

Fig. 2

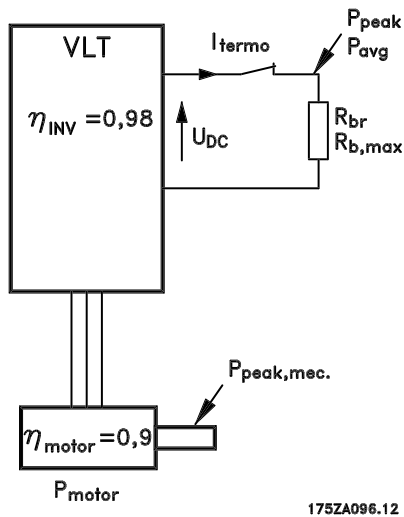

■ Calculation of brake resistor values

To keep the VLT frequency converter from cutting out for protection when the motor brakes, the resistor values are to be selected on the basis of the peak braking power and the intermediate circuit voltage:

$$R_{br} = \frac{U_{dc}^2}{P_{peak}} \quad [\Omega]$$

As can be seen, the brake resistor depends on the intermediate circuit voltage (Udc).

Udc is the voltage, where the brake is activated. For values see further on in this instruction.

Another option is to use the brake resistor recommended by Danfoss (Rrec). This guarantees that the frequency converter is able to brake at the highest braking torque (Mbr), i.e. 160% / 150% / 100%. See the tables further on in this instruction.

$$1) \quad R_{rec} = \frac{U_{dc}^2 \times 100}{P_{motor} \times M_{BR}(\%) \times \eta_{motor} \times \eta_{vlt}} \quad [\Omega]$$



**NB!:**

Remember to check whether your brake resistor is able to handle the intermediate voltage ( $U_{dc}$  for your specific drive can be found in the table below) if you do not use Danfoss brake resistors.

**$\eta_{motor}$  is typically 0,9, while  $\eta_{vlt}$  is typically 0,98.  $R_{rec}$  can be expressed as follows:**

VLT type	$U_{dc}$	Max. Braking torque	$R_{rec} =$
5001-5027 Process and FLUX / 200-240 Volt	397 Volt	160 %	$\frac{111.7}{P_{motor} [kW]} [\Omega]$
5032-5052 Process and FLUX / 200-240 Volt	390 Volt	150 %	$\frac{115.0}{P_{motor} [kW]} [\Omega]$
5001-5062, 5072 and 5102 Process and FLUX / 380-500 Volt	822 Volt	160 %	$\frac{478.8}{P_{motor} [kW]} [\Omega]$
5075, 5100 and 5125-5500 Process / 380-500 Volt	795 Volt	150 %	$\frac{477.7}{P_{motor} [kW]} [\Omega]$
5075, 5100 and 5125-5500 FLUX / 380-500 Volt	795 Volt	100 %	$\frac{477.7}{P_{motor} [kW]} [\Omega]$
5001-5250 Process / 550-600 Volt	958 Volt	160 %	$\frac{650.3}{P_{motor} [kW]} [\Omega]$
2803-2840 / 200-240 Volt	385 Volt	160 %	$\frac{105.0}{P_{motor} [kW]} [\Omega]$
2805-2882 and FCD 303-335 / 380-480 Volt	770 Volt	160%	$\frac{420.1}{P_{motor} [kW]} [\Omega]$

Calculation of the brake resistor



**NB!:**

Choose a brake resistor which is max. 10% below the value recommended by Danfoss.

If a bigger brake resistor is selected, 160% / 150% / 100% braking torque cannot be obtained, and there is a risk that the frequency converter will cut out for protection.

If braking is only e.g. at 80% torque, it is possible to install a bigger brake resistor, the size of which can be calculated using the formula  $R_{rec}$ , no. 1.

determined by the process period time, i.e. the length of the braking time in relation to the process period time. The peak power is determined by the braking torque, which means that as braking progresses, the brake resistor must be able to dissipate the energy input.

Fig. 3 shows the relation between the average power and the peak power.

**Fig. 3**

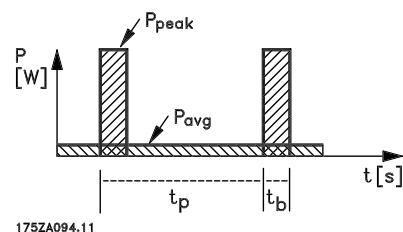

**■ Calculation of braking power**

When calculating the braking power, it is to be ensured that the brake resistor is able to handle the average power as well as the peak power. The average power is



**■ Calculation of the brake resistor peak power**

$P_{\text{peak, mec}}$  is the peak power by which the motor brakes on the motor shaft. It is calculated as follows:

$$P_{\text{peak, mec}} = P_{\text{motor}} \times M_{\text{RR}}(\%) \quad [\text{W}]$$

$P_{\text{peak}}$  is the name used for the braking power dissipated to the brake resistor when the motor brakes.

$P_{\text{peak}}$  is lower than  $P_{\text{peak, mec}}$  since the power is reduced by the efficiencies of the motor and the VLT frequency converter.

The peak power is calculated as follows:

$$P_{\text{peak}} = P_{\text{motor}} \times M_{\text{RR}}(\%) \times \eta_{\text{motor}} \times \eta_{\text{vlt}} \quad [\text{W}]$$

If the brake resistor recommended by Danfoss is selected ( $R_{\text{rec}}$ ) on the basis of the tables further on in this instruction, the brake resistor will be certain to provide a braking torque of 160% / 150% / 100% on the motor shaft.

**■ Calculation of the brake resistor average power**

The average power is determined by the process period time, i.e. the length of the braking time in relation to the process period time.

If the amount of kinetic energy ( $E_b$ ) transferred to the resistor in each braking sequence (see examples 1 and 2) is known, the average power of the resistor can be calculated as follows:

$$P_{\text{avg}} = \frac{E_b}{T_p} \quad [\text{W}]$$

$T_p$  = period time in seconds (see drawing on page 3).

If the amount of kinetic energy transferred to the resistor in each braking sequence is not known, the average power can be calculated on the basis of the process period time and the braking time.

The duty-cycle for the braking sequence is calculated as follows:

$$\text{Duty - cycle} = \frac{T_b \times 100}{T_p} \quad [\%]$$

$T_p$  = process period time in seconds.

$T_b$  = braking time in seconds.

Danfoss offers brake resistors with a duty-cycle of max. 10% and 40%, respectively (some drives are only available with a duty-cycle of max. 10%). If a 10% duty-cycle is applied, the brake resistors are able to absorb  $P_{\text{peak}}$  for 10% of the period time. The remaining 90% of the period time will be used on deflecting excess heat.

The average power with 10% duty-cycle can be calculated as follows:

$$P_{\text{avg}} = P_{\text{peak}} \times 10\% \quad [\text{W}]$$

The average power with 40% duty-cycle can be calculated as follows:

$$P_{\text{avg}} = P_{\text{peak}} \times 40\% \quad [\text{W}]$$

The calculations apply to intermittent braking using a period time of 120/300 seconds (to define whether it is 120 or 300 seconds. Please see the tables further on).

**NB!:**

Longer time than the specified intermittent braking period time may result in overheating of the resistor.

---

### ■ Braking of inertia

In the case of braking of high inertia values on the motor shaft, the brake resistor values can be based on the inertia,  $\Delta\omega$ ,  $\Delta t$ . See fig. 4.

Fig. 4

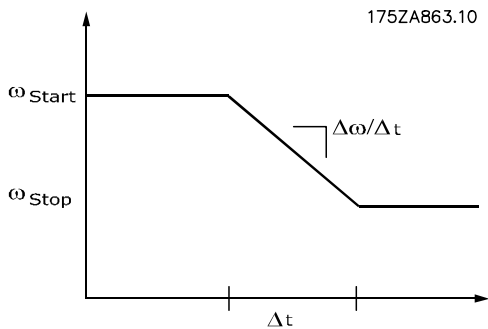

$\Delta t$  is determined by the ramp-down time in parameter 208.



#### NB!:

The ramp-down time goes from the rated motor frequency in parameter 104 to 0 Hz.

$P_{peak}$  can be calculated as:

$$P_{peak} = \eta_{motor} \times \eta_{vlt} \times \omega_{start} \times j \times \frac{\Delta\omega}{\Delta t}$$

$$P_{peak} = \eta_{motor} \times \eta_{vlt} \times n_{start} \times j \times \left( \frac{2 \times \pi}{60} \right)^2 \times \frac{\Delta n}{\Delta t}$$

$j$  is the inertia of the motor shaft.

Calculate the value on the brake resistor as described under the preceding paragraphs.

### ■ Continuous braking

For continuous braking, select a brake resistor in which the constant braking power does not exceed the average power  $P_{avg}$  of the brake resistor.



#### NB!:

Please contact your Danfoss distributor for further information.

### ■ D.C. injection braking

If the three-phase winding of the stator is fed with direct current, a stationary magnetic field  $\Phi$  will be set up in the stator bore causing a voltage to be induced in the bars of the cage rotor as long as the rotor is in motion.

Since the electrical resistance of the rotor cage is very low, even small induced voltages can create a high rotor current. This current will produce a strong braking effect on the bars and hence on the rotor. As the speed falls, the frequency of the induced voltage falls and with it the inductive impedance. The ohmic resistance of the rotor gradually becomes dominant and so increases the braking effect as the speed comes down. The braking torque generated falls away steeply just before standstill and finally ceases when there is no further movement. Direct current injection braking is therefore not suitable for actually holding a load at rest.

### ■ AC-braking VLT 2800 and FCD 300

When the motor acts as a brake the DC-link voltage will increase because energy is fed back to the DC-link. The principle in AC-brake is to increase the magnetisation during the braking and thereby increase the thermal losses of the motor. Using par. 144 in VLT 2800 and FCD 300 it is possible to adjust the size of the generator torque that can be applied to the motor without the intermediate circuit voltage exceeding the warning level.

The braking torque depends on the speed. With the AC-brake function enabled and parameter 144 = 1,3 (factory setting) it is possible to brake with about 50 % of rated torque below 2/3 of rated speed and with about 25 % at rated speed. The function is not working at low speed (below 1/3 of nominal motor speed). It is only possible to run for about 30 seconds with parameter 144 greater than 1.2.



#### NB!:

If the value in parameter 144 is increased, the motor current will simultaneously increase significantly when generator loads are applied.

The parameter should therefore only be changed if it is guaranteed during measurement that the motor current in all operating situations will never exceed the maximum permitted current in the motor. Please note: The current can not be read out from the display.

### ■ Optimum braking

Dynamic braking is useful from max. speed down to a certain frequency. Below this frequency DC braking is to be applied as required. The most efficient way of doing this is to use a combination of dynamic and DC braking. See fig. 5. The parameters can be found further on in this instruction.

Fig. 5

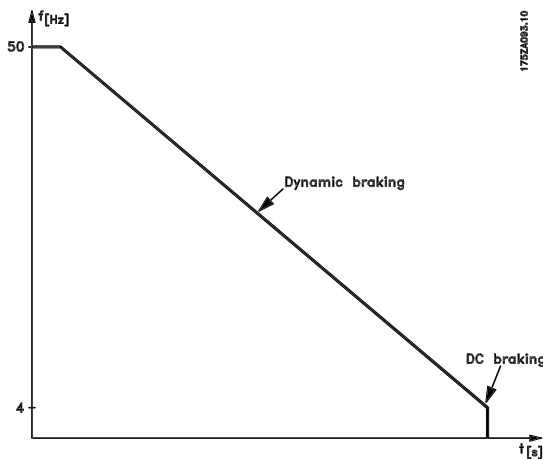

**NB!:**

When changing from dynamic to DC braking, there will be a short period (2-6 milliseconds) with very low braking torque.



**NB!:**

The brake resistor is to be fitted on a non-flammable material.

For protection of the installation, a thermal relay should be fitted that cuts off the frequency converter if the brake current becomes too high.

Calculate the brake current setting of the thermal relay as follows:

$$I_{\text{therm relay}} = \sqrt{\frac{P_{\text{brake resistor max}}}{R_{\text{brake resistor}}}}$$

$R_{br}$  is the current brake resistor value calculated in the section on "Calculation of brake resistor values". Fig. 6 shows an installation with a thermal relay.

The brake current setting of thermal relay for Danfoss brake resistors can be found in tables further on in this instruction.

How to calculate optimum DC-brake cut in frequency:

$$\text{Slip } S = \frac{n_0 - n_n}{n_0} \times 100 \quad [\%]$$

$$\text{Synchronous speed } n_0 = \frac{f \times 60}{p} \quad [1/\text{min}]$$

f = frequency

p = no. of pole pairs

$n_n$  = speed of the rotor

$$\text{DC-brake cut in frequency} = 2 \times \frac{S \times f}{100} \quad [\text{Hz}]$$

**■ Brake cable**

Max. length [m]: 20 m

The connection cable to the brake resistor is to be screened/armoured. Connect the screen/armouring to the conductive back plate at the VLT frequency converter and to the brake resistor metal cabinet by means of cable clamps.



**NB!:**

If Danfoss brake resistors are not used, make sure that the brake resistors used are induction-free.

**■ Protective functions during installation**

When installing a brake resistor, every measure should be taken to avoid the risk of overloading, since a fire hazard may arise owing to the heat generated in the heat resistor.

Fig. 6

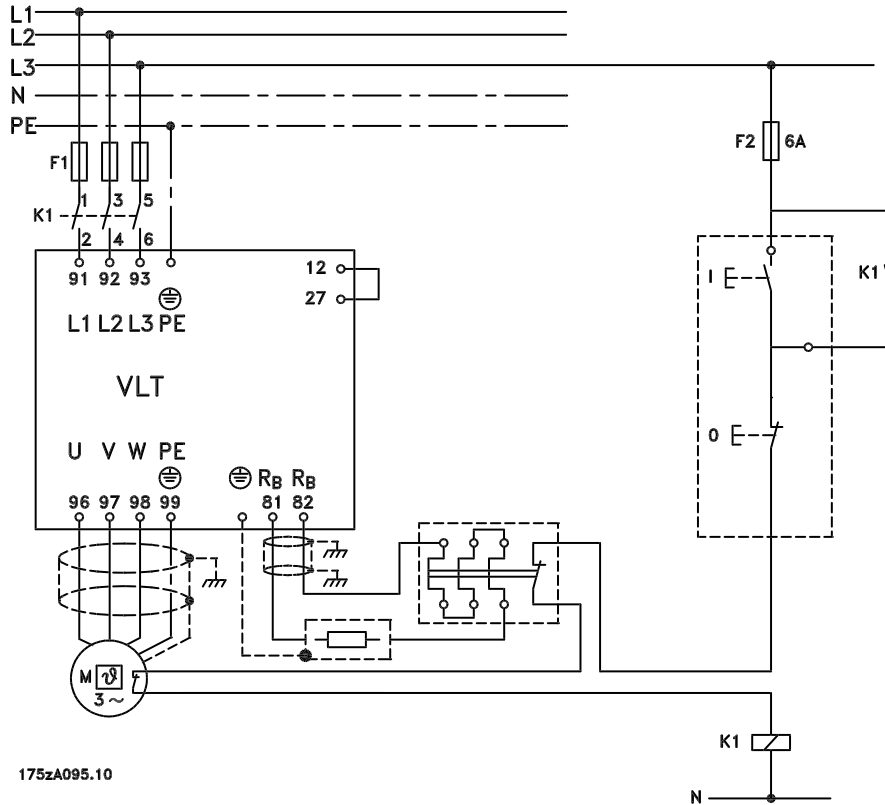

Some of the Danfoss Brakeresistors contain a thermal switch (see tables further on in this instruction). This switch is NC (normally closed) and can be used e.g. coasting stop reverse between terminal 12 and 27. The drive will then coast, if the thermal switch is opened.



**NB!:**

The thermal switch is not a protective device. For protection, use a thermal switch as shown in fig. 6.

Via the digital/relay outputs, it is possible to get a status message concerning the brake, e.g. indicating brake faults. Furthermore, VLT 5000 Series features an integral function to check whether the brake resistor has been connected/is intact at the time of power-up.

Additionally, the brake is protected against short-circuiting by the brake resistor. The brake circuit is not earthing proof.

■ **Description of VLT 5000 brake**

Danfoss VLT 5000 Series enables activation of an integral brake monitor to guarantee that the braking power does not exceed a given limit.

The power is calculated on the basis of the resistor ohm value (parameter 401), the intermediate circuit voltage and the resistor running time. For further information, see page 10.



**NB!:**

The brake power monitoring system is not a protective device. For protection, use a thermal switch as shown in fig. 6.

**■ VLT 5000 Process parameters**

The following is a list of parameters for the VLT 5000 Process Series which are important or relevant for the dynamic brake and the DC brake.

<b>Parameter</b>	<b>Suggestion of settings</b>
125 DC braking current	Depends on the desired braking torque
126 DC braking time	Set the desired DC braking time
127 DC brake cut-in frequency	Set the desired DC brake cut-in frequency
222 Torque limit for generating operation	160 %
319 Output (terminal 42)	Brake no warning, Brake ready no fault or Brake fault
321 Output (terminal 45)	Same as 319
323 Output (relay 01)	Same as 319
326 Output (relay 4)	Same as 319
400 Brake function/overvoltage control	Resistor brake
401 Brake resistor, ohm	Depends on the unit, see the tables further on in this instruction
402 Brake power limit, kW	Depends on the unit, see the tables further on in this instruction
403 Power monitoring	Warning or trip
404 Brake check	Warning or trip

**■ VLT 5000 FLUX parameters**

The following is a list of parameters for the VLT 5000 FLUX Series which are important or relevant for the dynamic brake and the DC brake.

<b>Parameter</b>	<b>Suggestion of settings</b>
125 DC braking current	Depends on the desired braking torque
126 DC braking time	Set the desired DC braking time
127 DC brake cut-in frequency	Set the desired DC brake cut-in frequency
222 Torque limit for generating operation	160 %
323 Output (relay 01)	Brake no warning, Brake ready no fault or Brake fault
326 Output (relay 4)	Same as 323
341 Output (terminal 46)	Same as 323
355 Output (terminal 26)	Same as 323
400 Brake function/overvoltage control	Resistor brake
401 Brake resistor, ohm	Depends on the unit, see the tables further on in this instruction
402 Brake power limit, kW	Depends on the unit, see the tables further on in this instruction
403 Power monitoring	Warning or trip
404 Brake check	Warning or trip

The sizes VLT 5125 and 5150 are equipped with a better dynamic brake performance compared to the same sizes in VLT 5000 Process.

It is possible to brake 4 min out 10 min in a total cycle (Duty type S% 40% EN 60034-1)

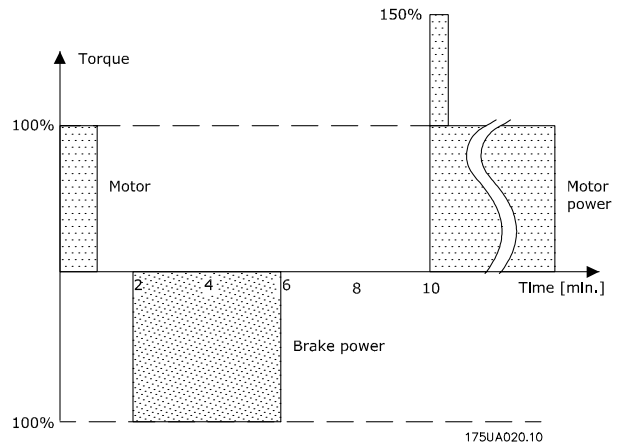
**VLT 5125 FLUX and VLT 5150 FLUX**

**■ VLT 2800 parameters**

The following is a list of parameters for the VLT 2800 Series which are important or relevant for the dynamic brake and the DC brake.

Parameter	Suggestion of settings
126 DC braking time	Set the desired DC braking time
127 DC brake engaging frequency	Set the desired DC brake engaging frequency
132 DC brake voltage	Depends on the desired braking torque
400 Brake function	Resistor or AC brake
456 Brake voltage reduce	0 should only be used if there are problems with overvoltage in the intermediate circuit

**■ FCD 300 parameters**

The following is a list of parameters for the VLT FCD 300 Series which are important or relevant for the dynamic brake and the DC brake.

Parameter	Suggestion of settings
126 DC braking time	Set the desired DC braking time
127 DC brake engaging frequency	Set the desired DC brake engaging frequency
132 DC brake voltage	Depends on the desired braking torque
400 Brake function	Resistor or AC brake
456 Brake voltage reduce	0 should only be used if there are problems with overvoltage in the intermediate circuit

**■ Brake resistor for VLT 5001-5500 10% duty-cycle  
data and codenumber**

VLT type P=Process F=FLUX	Intermittent braking period time [seconds]	P <sub>motor</sub> [kW]	R <sub>min</sub> [Ω]	R <sub>rec</sub> [Ω]	P <sub>b, max</sub> [kW]	Therm. relay [Amp]	Code number 175Uxxxx	Cable cross section [mm <sup>2</sup> ]
5001 P, F (200V)	120	0,75	130	145	0,065	0,7	1820	1,5*****
5002 P, F (200V)	120	1,1	81	90	0,095	1,0	1821	1,5*****
5003 P, F (200V)	120	1,5	58	65	0,25	2,0	1822	1,5*****
5004 P, F (200V)	120	2,2	45	50	0,285	2,4	1823	1,5*****
5005 P, F (200V)	120	3,0	31	35	0,43	2,5	1824	1,5*****
5006 P, F (200V)	120	4,0	22	25	0,8	5,7	1825	1,5*****
5008 P, F (200V)	120	5,5	18	20	1,0	7,1	1826	1,5*****
5011 P, F (200V)	120	7,5	13	15	2,0	11	1827	1,5*****
5016 P, F (200V)	120	11,0	9,0	10	2,8	17	1828	2,5*****
5022 P, F (200V)	120	15,0	6,3	7,0	4,0	24	1829	4*****
5027 P, F (200V)	120	18,5	5,2	6,0	4,8	28	1830	4*****
5032 P, F (200V)	300	22,0	4,2	4,7	6,0	36	1954	10*****
5042 P, F (200V)	300	30,0	3,0	3,3	8,0	49	1955	10*****
5052 P, F (200V)	300	37,0	2,4	2,7	10,0	61	1956	16*****
5001 P, F (500V)	120	0,75	557	620	0,065	0,3	1840	1,5*****
5002 P, F (500V)	120	1,1	382	425	0,095	0,5	1841	1,5*****
5003 P, F (500V)	120	1,5	279	310	0,25	0,9	1842	1,5*****
5004 P, F (500V)	120	2,2	189	210	0,285	1,2	1843	1,5*****
5005 P, F (500V)	120	3,0	135	150	0,43	1,7	1844	1,5*****
5006 P, F (500V)	120	4,0	99	110	0,6	2,3	1845	1,5*****
5008 P, F (500V)	120	5,5	72	80	0,85	3,3	1846	1,5*****
5011 P, F (500V)	120	7,5	58,5	65	1,0	3,9	1847	1,5*****
5016 P, F (500V)	120	11,0	36	40	2,0	7,1	1848	1,5*****
5022 P, F (500V)	120	15,0	27	30	2,8	9,7	1849	1,5*****
5027 P, F (500V)	120	18,5	22	25	3,5	12	1850	1,5*****
5032 P, F (500V)	120	22,0	18	20	4,0	14	1851	1,5*****
5042 P, F (500V)	120	30,0	13	15	4,8	18	1852	2,5*****
5052 P, F (500V)	120	37,0	10,8	12	5,5	21	1853	2,5*****
5060 P, F (500V)****	300	45,0	7,0	7,8	12	39	N.A.	10*****
5062 P, F (500V)	120	45,0	9,8	9,8	15	39	2008	10*****
5072 P, F (500V)	120	55,0	7,3	7,3	13	42	0069	10*****
5075 P (500V)*	300	55,0	5,1	5,7	14	50	1958	10*****
5075 F (500V) *	600*****	55,0	5,1	5,7	21	61	0076	16*****
5100 P (500V)**	300	75,0	4,2	4,7	18	62	1959	16*****
5100 F (500V)**	600*****	75,0	4,2	4,7	29	79	0077	25*****
5102 P, F (500V)	120	75,0	5,7	6,33	15	49	0067	10*****
5125 P (500V)	300	90,0	3,4	3,8	22	76	1960	25*****
5125 F (500V)	600*****	90,0	3,4	3,8	36	97	0078	35*****
5150 P (500V)	300	110	2,9	3,2	27	92	1961	35*****
5150 F (500V)	600*****	110	2,9	3,2	42	115	0079	50*****
5200 P, F (500V)	300	132	2,3	2,6	32	111	1962	50*****
5250 P, F (500V)	300	160	1,9	2,1	39	136	1963	70*****

VLT type P=Process F=FLUX	Intermittent braking period time [seconds]	P <sub>motor</sub> [kW]	R <sub>min</sub> [Ω]	R <sub>rec</sub> [Ω]	P <sub>b, max</sub> [kW]	Therm. relay [Amp]	Code number 175Uxxxx	Cable cross section [mm <sup>2</sup> ]
5300 P, F (500V)	300	200	3,14	3,3	56	130	2 x 1061***	50*****
5350 P, F (500V)	300	250	2,47	2,6	72	166	2 x 1062***	70*****
5450 P, F (500V)	300	315	2,19	2,3	90	198	2 x 1063***	95*****
5500 P, F (500V)	300	355	2,00	2,1	100	218	2 x 1064***	120*****
5001 P (600V)	120	0,75	797	797	R.d.	****	N.A.	
5002 P (600V)	120	1,1	534	534	R.d.	****	N.A.	
5003 P (600V)	120	1,5	398	398	R.d.	****	N.A.	
5004 P (600V)	120	2,2	267	267	R.d.	****	N.A.	
5005 P (600V)	120	3,0	199	199	R.d.	****	N.A.	
5006 P (600V)	120	4,0	149	149	R.d.	****	N.A.	
5008 P (600V)	120	5,5	107	107	R.d.	****	N.A.	
5011 P (600V)	120	7,5	80	80	R.d.	****	N.A.	
5016 P (600V)	120	11,0	53,4	53,4	R.d.	****	N.A.	
5022 P (600V)	120	15,0	39,8	39,8	R.d.	****	N.A.	
5027 P (600V)	120	18,5	32,0	32,0	R.d.	****	N.A.	
5032 P (600V)	120	22,0	26,7	26,7	R.d.	****	N.A.	
5042 P (600V)	120	30,0	19,9	19,9	R.d.	****	N.A.	
5052 P (600V)	120	37,0	16,0	16,0	R.d.	****	N.A.	
5062 P (600V)	120	45,0	13,3	13,3	R.d.	****	N.A.	
5075 P (600V)	300	55,0	11,0	11,0	R.d.	****	N.A.	
5100 P (600V)	300	75,0	8,2	8,2	R.d.	****	N.A.	
5125 P (600V)	300	90,0	6,8	6,8	R.d.	****	N.A.	
5150 P (600V)	300	110	5,6	5,6	R.d.	****	N.A.	
5200 P (600V)	300	132	4,3	4,3	R.d.	****	N.A.	
5250 P (600V)	300	160	3,3	3,3	R.d.	****	N.A.	

**Brake resistor  
overview**

\*to be replaced by VLT 5072

\*\*to be replaced by VLT 5102

\*\*\*Order 2 pcs.

\*\*\*\*Replaced by VLT 5062

\*\*\*\*\*I<sub>therm relay</sub> =  $\sqrt{\frac{P_{\text{brakeresistor max}}}{R_{\text{brakeresistor}}}}$

\*\*\*\*\*Always observe national and local regulations

\*\*\*\*\* Please observe drawing at VLT 5000 FLUX parameters

- P<sub>motor</sub> : Rated motor size for VLT type
- R<sub>min</sub> : Minimum permissible brake resistor
- R<sub>rec</sub> : Recommended brake resistor (Danfoss)
- P<sub>b, max</sub> : Brake resistor rated power as stated by supplier
- Therm. relay : Brake current setting of thermal relay
- Code number : Order numbers for Danfoss brake resistors
- Cable cross section : Recommended minimum value based upon PVC insulated cober cable, 30 degree Celsius ambient temperature with normal heat dissipation
- R.d. : Resistor dependent



**■ Brake resistor for VLT 5001-5102 40% duty-cycle  
data and codenumber**

VLT type P=Process F=FLUX	Intermittent braking period time [seconds]	P <sub>motor</sub> [kW]	R <sub>min</sub> [Ω]	R <sub>rec</sub> [Ω]	P <sub>b, max</sub> [kW]	Therm.re- lay [Amp]	Code number 175Uxxxx	Cable cross section [mm <sup>2</sup> ]
5001 P, F (200V)	120	0,75	130	145	0,26	1,3	1920	1,5**
5002 P, F (200V)	120	1,1	81	90	0,43	2,2	1921	1,5**
5003 P, F (200V)	120	1,5	58	65	0,8	3,5	1922	1,5**
5004 P, F (200V)	120	2,2	45	50	1,0	4,5	1923	1,5**
5005 P, F (200V)	120	3,0	31	35	1,35	6,2	1924	1,5**
5006 P, F (200V)	120	4,0	22	25	3,0	11,0	1925	1,5**
5008 P, F (200V)	120	5,5	18	20	3,5	13,0	1926	1,5**
5011 P, F (200V)	120	7,5	13	15	5,0	18,0	1927	2,5**
5016 P, F (200V)	120	11,0	9	10	9,0	30,0	1928	10**
5022 P, F (200V)	120	15,0	6,5	7	10,0	38,0	1929	16**
5027 P, F (200V)	120	18,5	5,2	6	12,7	46,0	1930	16**
5001 P, F (500V)	120	0,75	557	620	0,26	0,6	1940	1,5**
5002 P, F (500V)	120	1,1	382	425	0,43	1,0	1941	1,5**
5003 P, F (500V)	120	1,5	279	310	0,8	1,6	1942	1,5**
5004 P, F (500V)	120	2,2	189	210	1,35	2,5	1943	1,5**
5005 P, F (500V)	120	3,0	135	150	2,0	3,7	1944	1,5**
5006 P, F (500V)	120	4,0	99	110	2,4	4,7	1945	1,5**
5008 P, F (500V)	120	5,5	72	80	3,0	6,1	1946	1,5**
5011 P, F (500V)	120	7,5	59	65	4,5	8,3	1947	1,5**
5016 P, F (500V)	120	11,0	36	40	5,0	11	1948	1,5**
5022 P, F (500V)	120	15,0	27	30	9,3	18	1949	2,5**
5027 P, F (500V)	120	18,5	22	25	12,7	23	1950	4**
5032 P, F (500V)	120	22,0	18	20	13,0	25	1951	4**
5042 P, F (500V)	120	30,0	14	15	15,6	32	1952	10**
5052 P, F (500V)	120	37,0	10	12	19,0	40	1953	16**
5062 P, F (500V)	120	45,0	9,8	9,8	38,0	62	2007	16**
5072 P, F (500V)	120	55,0	7,3	7,3	38,0	72	0068	25**
5102 P, F (500V)	120	75,0	5,7	6,0	45,0	87	0066	25**
5125 F (500V)	600***	90,0	3,4	3,8	75	140	2 x 0072	2 x 70 **
5150 F (500V)	600***	110	2,9	3,2	90	168	2 x 0073	2 x 70 **
5001 P (600V)	120	0,75	797	797	R.d.	*	N.A.	
5002 P (600V)	120	1,1	534	534	R.d.	*	N.A.	
5003 P (600V)	120	1,5	398	398	R.d.	*	N.A.	
5004 P (600V)	120	2,2	267	267	R.d.	*	N.A.	
5005 P (600V)	120	3,0	199	199	R.d.	*	N.A.	
5006 P (600V)	120	4,0	149	149	R.d.	*	N.A.	
5008 P (600V)	120	5,5	107	107	R.d.	*	N.A.	
5011 P (600V)	120	7,5	80	80	R.d.	*	N.A.	
5016 P (600V)	120	11,0	53,4	53,4	R.d.	*	N.A.	
5022 P (600V)	120	15,0	39,8	39,8	R.d.	*	N.A.	
5027 P (600V)	120	18,5	32,0	32,0	R.d.	*	N.A.	

VLT type P=Process F=FLUX	Intermittent braking period time [seconds]	P <sub>motor</sub> [kW]	R <sub>min</sub> [Ω]	R <sub>rec</sub> [Ω]	P <sub>b, max</sub> [kW]	Therm.re- lay [Amp]	Code number 175Uxxxx	Cable cross section [mm <sup>2</sup> ]
5032 P (600V)	120	22,0	26,7	26,7	R.d.	*	N.A.	
5042 P (600V)	120	30,0	19,9	19,9	R.d.	*	N.A.	
5052 P (600V)	120	37,0	16,0	16,0	R.d.	*	N.A.	
5062 P (600V)	120	45,0	13,3	13,3	R.d.	*	N.A.	

$$I_{\text{therm relay}} = \sqrt{\frac{P_{\text{brake resistor max}}}{R_{\text{brake resistor}}}}$$

\*\*Always observe national and local regulations

\*\*\* Please observe drawing at VLT 5000 Flux parameters

- P<sub>motor</sub> : Rated motor size for VLT type  
 R<sub>min</sub> : Minimum permissible brake resistor  
 R<sub>rec</sub> : Recommended brake resistor (Danfoss)  
 P<sub>b, max</sub> : Brake resistor rated power as stated by supplier  
 Therm. relay : Brake current setting of thermal relay  
 Code number : Order numbers for Danfoss brake resistors  
 Cable cross section : Recommended minimum value based upon PVC insulated cober cable, 30 degree Celsius ambient temperature with normal heat dissipation  
 R.d. : Resistor dependent

■ **Brake resistor for VLT 2803-2882 duty-cycle  
40% data and codenumber**

VLT type	Intermit- tent brak- ing period time [seconds]	P <sub>motor</sub> [kW]	R <sub>min</sub> [Ω]	R <sub>rec</sub> [Ω]	P <sub>b, max</sub> [kW]	Therm.re- lay [Amp]	Code number 175Uxxxx	Cable cross section [mm <sup>2</sup> ]
2803 (200 V)	120	0,37	297	330	0,16	0,7	1900*	1,5**
2805 (200 V)	120	0,55	198	220	0,25	1,1	1901*	1,5**
2807 (200 V)	120	0,75	135	150	0,32	1,5	1902*	1,5**
2811 (200 V)	120	1,1	99	110	0,45	2,0	1975*	1,5**
2815 (200 V)	120	1,5	74	82	0,85	3,2	1903*	1,5**
2822 (200 V)	120	2,2	50	56	1,00	4,2	1904*	1,5**
2840 (200 V)	120	3,7	22	25	3,00	11,0	1925	1,5**
2805 (400 V)	120	0,55	747	830	0,45	0,7	1976*	1,5**
2807 (400 V)	120	0,75	558	620	0,32	0,7	1910*	1,5**
2811 (400 V)	120	1,1	387	430	0,85	1,4	1911*	1,5**
2815 (400 V)	120	1,5	297	330	0,85	1,6	1912*	1,5**
2822 (400 V)	120	2,2	198	220	1,00	2,1	1913*	1,5**
2830 (400 V)	120	3,0	135	150	1,35	3,0	1914*	1,5**
2840 (400 V)	120	4,0	99	110	1,60	3,8	1979*	1,5**
2855 (400 V)	120	5,5	80	80	2,00	5,0	1977*	1,5**
2875 (400 V)	120	7,5	56	56	3,00	6,8	1978*	1,5**
2880 (400 V)	120	11	40	40	5,00	11,2	1997*	1,5**
2881 (400 V)	120	15	30	30	10,0	18,3	1998	2,5**
2882 (400 V)	120	18,5	25	25	13,0	22,8	1999	4**

\*With KLIXON switch

\*\*Always observe national and local regulations

**■ Brake resistor for VLT FCD 303-335 duty-cycle  
40% data and codenumber**

VLT type	Intermittent braking period time [seconds]	P <sub>motor</sub> [kW]	R <sub>min</sub> [Ω]	R <sub>rec</sub> [Ω]	P <sub>b, max</sub> [kW]	Therm. relay [Amp]	Code number 175Uxxxx	Cable cross section [mm <sup>2</sup> ]
303 (400 V)	120	0,37	520	830	0,45	0,7	1976	1,5*
305 (400 V)	120	0,55	405	830	0,45	0,7	1976	1,5*
307 (400 V)	120	0,75	331	620	0,32	0,7	1910	1,5*
311 (400 V)	120	1,1	243	430	0,85	1,4	1911	1,5*
315 (400 V)	120	1,5	197	330	0,85	1,6	1912	1,5*
322 (400 V)	120	2,2	140	220	1,00	2,1	1913	1,5*
330 (400 V)	120	3,0	104	150	1,35	3,0	1914	1,5*
335 (400 V)	120	3,3	104	150	1,35	3,0	1914	1,5*

\*Always observe national and local regulations

- P<sub>motor</sub> : Rated motor size for VLT type
- R<sub>min</sub> : Minimum permissible brake resistor
- R<sub>rec</sub> : Recommended brake resistor (Danfoss)
- P<sub>b, max</sub> : Brake resistor rated power as stated by supplier
- Therm. relay : Brake current setting of thermal relay
- Code number : Order numbers for Danfoss brake resistors
- Cable cross section : Recommended minimum value based upon PVC insulated cober cable, 30 degree Celsius ambient temperature with normal heat dissipation

**■ Brake resistor for VLT 5001-5500 10% duty-cycle cablegland, weight and drawing no.**

VLT type P=Process F=FLUX	Cablegland	Weight [kg]	Code number 175Uxxxx	Drawing No.
5001 P, F (200V)	PG 9	1,1	1820	1
5002 P, F (200V)	PG 9	1,1	1821	1
5003 P, F (200V)	PG 9	2,1	1822	3
5004 P, F (200V)	PG 9	2,1	1823	3
5005 P, F (200V)	PG 9	2,2	1824	4
5006 P, F (200V)	PG 9	3,0	1825	6
5008 P, F (200V)	PG 9	3,5	1826	7
5011 P, F (200V)	PG 16	5,8	1827	9
5016 P, F (200V)	PG 21	13,5	1828	12
5022 P, F (200V)	PG 21	15,0	1829	12
5027 P, F (200V)	PG 21	16,5	1830	12
5032 P, F (200V)	PG 21	19,0	1954	12
5042 P, F (200V)	PG 21	20,0	1955	13
5052 P, F (200V)	PG 21	32,0	1956	14
5001 P, F (500V)	PG 9	1,1	1840	1
5002 P, F (500V)	PG 9	1,2	1841	2
5003 P, F (500V)	PG 9	2,1	1842	3
5004 P, F (500V)	PG 9	2,1	1843	3
5005 P, F (500V)	PG 9	2,2	1844	4
5006 P, F (500V)	PG 9	2,4	1845	5
5008 P, F (500V)	PG 9	3,0	1846	6
5011 P, F (500V)	PG 9	3,5	1847	7
5016 P, F (500V)	PG 16	5,8	1848	9
5022 P, F (500V)	PG 16	13,5	1849	12
5027 P, F (500V)	PG 16	15,0	1850	12
5032 P, F (500V)	PG 16	15,0	1851	12
5042 P, F (500V)	PG 21	16,5	1852	12
5052 P, F (500V)	PG 21	19,0	1853	12
5062 P, F (500V)	PG 21	36,0	2008	15
5072 P, F (500V)	PG 21	40,0	0069	15
5075 P (500V)	PG 21	49,0	1958	15
5075 F (500V)	PG 29	65,0	0076	17
5100 P (500V)	PG 21	52,0	1959	15
5100 F (500V)	PG 36	67,0	0077	17
5102 P, F (500V)	PG 21	40,0	0067	15
5125 P (500V)	PG 29	56,0	1960	16
5125 F (500V)	PG 36	90,0	0078	18
5150 P (500V)	PG 29	66,0	1961	17
5150 F (500V)	PG 36	94,0	0079	18
5200 P, F (500V)	PG 36	72,0	1962	17
5250 P, F (500V)	PG 36	125,0	1963	18
5300 P, F (500V)	PG 36	70/pcs	2 x 1061	2 x 17
5350 P, F (500V)	PG 36	90/pcs	2 x 1062	2 x 18
5450 P, F (500V)	PG 36	90/pcs	2 x 1063	2 x 18
5500 P, F (500V)	PG 42	125/pcs	2 x 1064	2 x 19

Brake resistor overview

■ Brake resistor for VLT 5001-5102 40% duty-cycle  
cablegland, weight and drawing no.

VLT type P=Process F=FLUX	Cablegland	Weight [kg]	Code number 175Uxxxx	Drawing No.
5001 P, F (200V)	PG 9	2,1	1920	3
5002 P, F (200V)	PG 9	2,2	1921	4
5003 P, F (200V)	PG 9	3,0	1922	6
5004 P, F (200V)	PG 9	3,5	1923	7
5005 P, F (200V)	PG 16	4,6	1924	8
5006 P, F (200V)	PG 16	13,5	1925	12
5008 P, F (200V)	PG 16	15,0	1926	12
5011 P, F (200V)	PG 21	16,5	1927	12
5016 P, F (200V)	PG 21	25,0	1928	14
5022 P, F (200V)	PG 21	25,0	1929	14
5027 P, F (200V)	PG 21	32,0	1930	15
5001 P, F (500V)	PG 9	2,1	1940	3
5002 P, F (500V)	PG 9	2,2	1941	4
5003 P, F (500V)	PG 9	3,0	1942	6
5004 P, F (500V)	PG 16	4,6	1943	8
5005 P, F (500V)	PG 16	5,8	1944	9
5006 P, F (500V)	PG 16	7,2	1945	10
5008 P, F (500V)	PG 16	7,6	1946	11
5011 P, F (500V)	PG 16	16,5	1947	12
5016 P, F (500V)	PG 16	17,0	1948	12
5022 P, F (500V)	PG 21	25,0	1949	14
5027 P, F (500V)	PG 21	32,0	1950	14
5032 P, F (500V)	PG 21	34,0	1951	15
5042 P, F (500V)	PG 21	35,0	1952	15
5052 P, F (500V)	PG 29	47,0	1953	16
5062 P, F (500V)	PG 36	95,0	2007	18
5072 P, F (500V)	PG 36	125	0068	18
5102 P, F (500V)	PG 36	150	0066	18
5125 F (500V)	PG 36	90/pcs	2 x 0072	2 x 18
5150 F (500V)	PG 36	95/pcs	2 x 0073	2 x 18

■ **Brake resistor for VLT 2803-2882 40% duty-cycle cableglad, weight and drawing no.**

VLT type	Cableglad	Weight [kg]	Code number 175Uxxxx	Drawing No.
2803 (200 V)	PG 7 (Thermo) / PG 9 (power)	1,2	1900	2
2805 (200 V)	PG 7 (Thermo) / PG 9 (power)	2,1	1901	3
2807 (200 V)	PG 7 (Thermo) / PG 9 (power)	2,1	1902	3
2811 (200 V)	PG 7 (Thermo) / PG 9 (power)	2,2	1975	4
2815 (200 V)	PG 7 (Thermo) / PG 9 (power)	2,4	1903	5
2822 (200 V)	PG 7 (Thermo) / PG 9 (power)	3,5	1904	7
2840 (200 V)	PG 16	13,5	1925	12
2805 (400 V)	PG 7 (Thermo) / PG 9 (power)	2,2	1976	4
2807 (400 V)	PG 7 (Thermo) / PG 9 (power)	2,2	1910	4
2811 (400 V)	PG 7 (Thermo) / PG 9 (power)	2,4	1911	5
2815 (400 V)	PG 7 (Thermo) / PG 9 (power)	3,0	1912	6
2822 (400 V)	PG 7 (Thermo) / PG 9 (power)	3,5	1913	7
2830 (400 V)	PG 7 (Thermo) / PG 16 (power)	4,6	1914	8
2840 (400 V)	PG 7 (Thermo) / PG 16 (power)	4,6	1979	8
2855 (400 V)	PG 7 (Thermo) / PG 16 (power)	5,8	1977	9
2875 (400 V)	PG 7 (Thermo) / PG 16 (power)	7,6	1978	11
2880 (400 V)	PG 21	17	1997	12
2881 (400 V)	PG 21	25	1998	14
2882 (400 V)	PG 21	34	1999	15

Brake resistor overview

■ **Brake resistor for VLT FCD 303-335 40% duty-cycle cableglad, weight and drawing no.**

VLT type	Cableglad	Weight [kg]	Code number 175Uxxxx	Drawing No.
303 (400 V)	PG 7 (Thermo) / PG 9 (power)	2,2	1976	4
305 (400 V)	PG 7 (Thermo) / PG 9 (power)	2,2	1976	4
307 (400 V)	PG 7 (Thermo) / PG 9 (power)	2,2	1910	4
311 (400 V)	PG 7 (Thermo) / PG 9 (power)	2,4	1911	5
315 (400 V)	PG 7 (Thermo) / PG 9 (power)	3,0	1912	6
322 (400 V)	PG 7 (Thermo) / PG 9 (power)	3,5	1913	7
330 (400 V)	PG 7 (Thermo) / PG 16 (power)	4,6	1914	8
335 (400 V)	PG 7 (Thermo) / PG 16 (power)	4,6	1914	8

■ Drawing no. 1

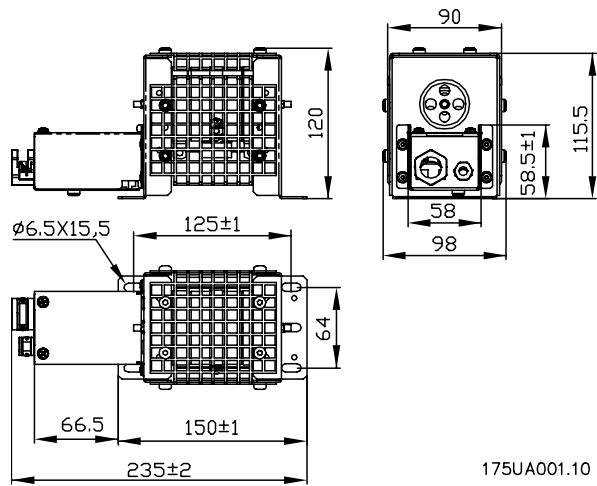

■ Drawing no. 2

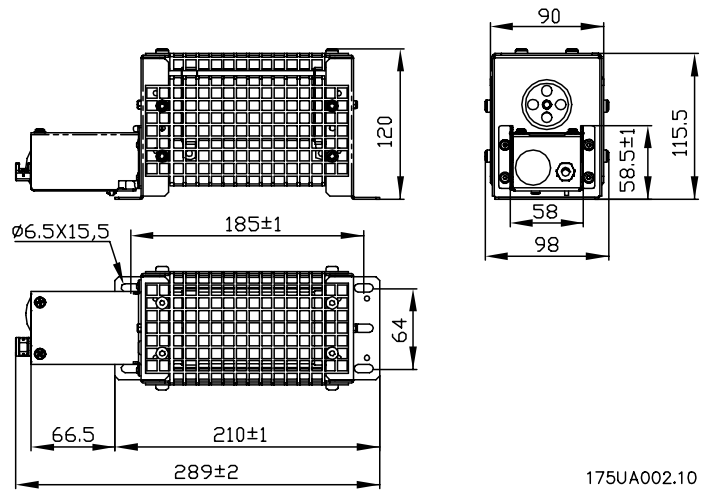

■ Drawing no. 3

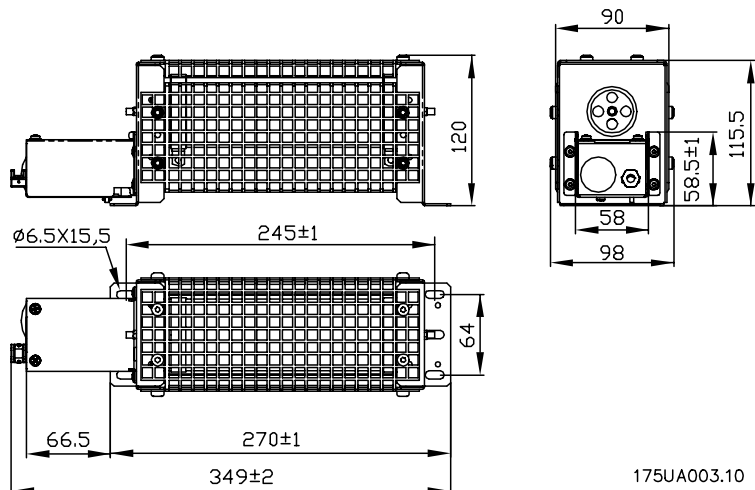

■ Drawing no. 4

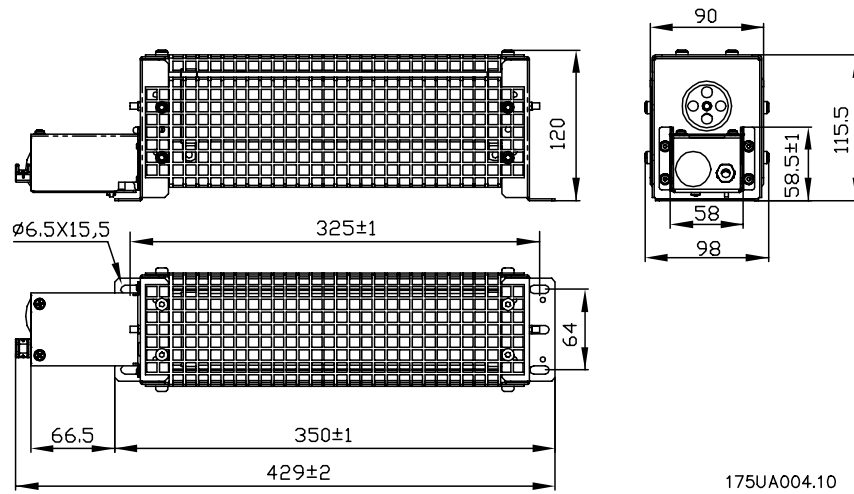

■ Drawing no. 5

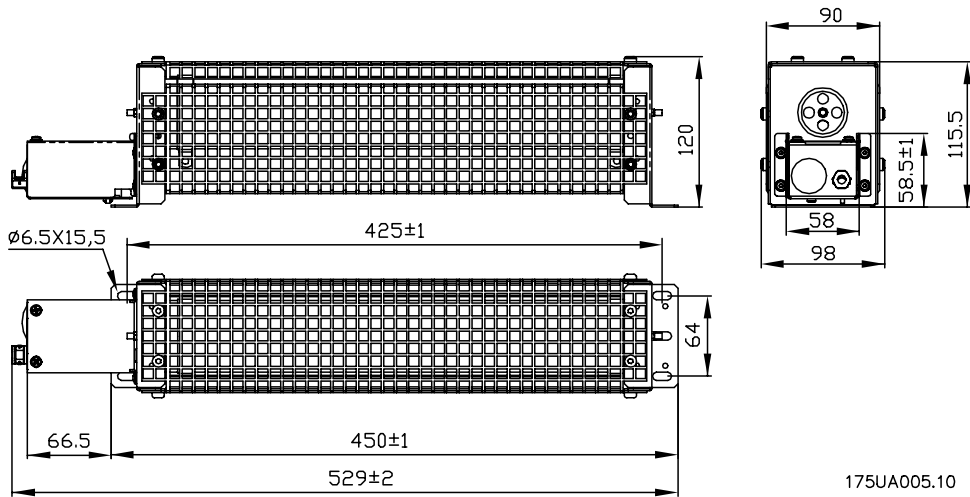

■ Drawing no. 6

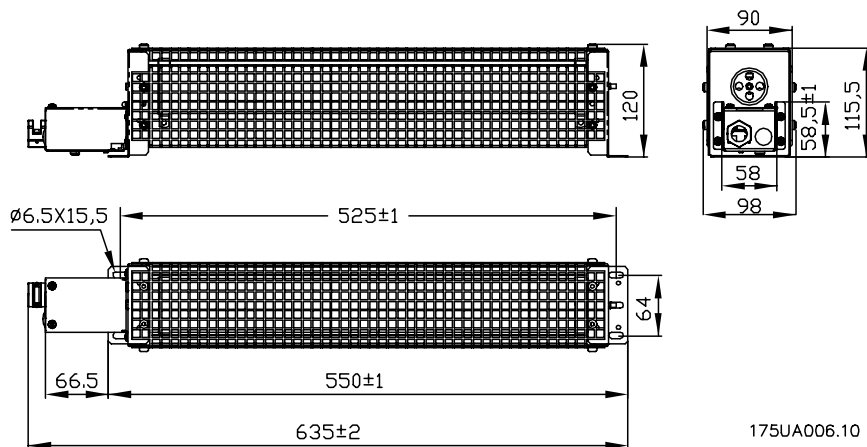

Drawings 1  
- 19



■ Drawing no. 7

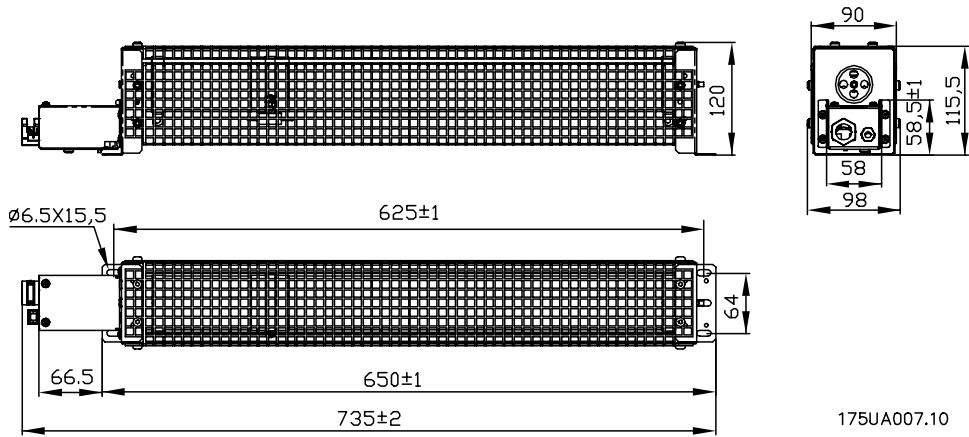

■ Drawing no. 8

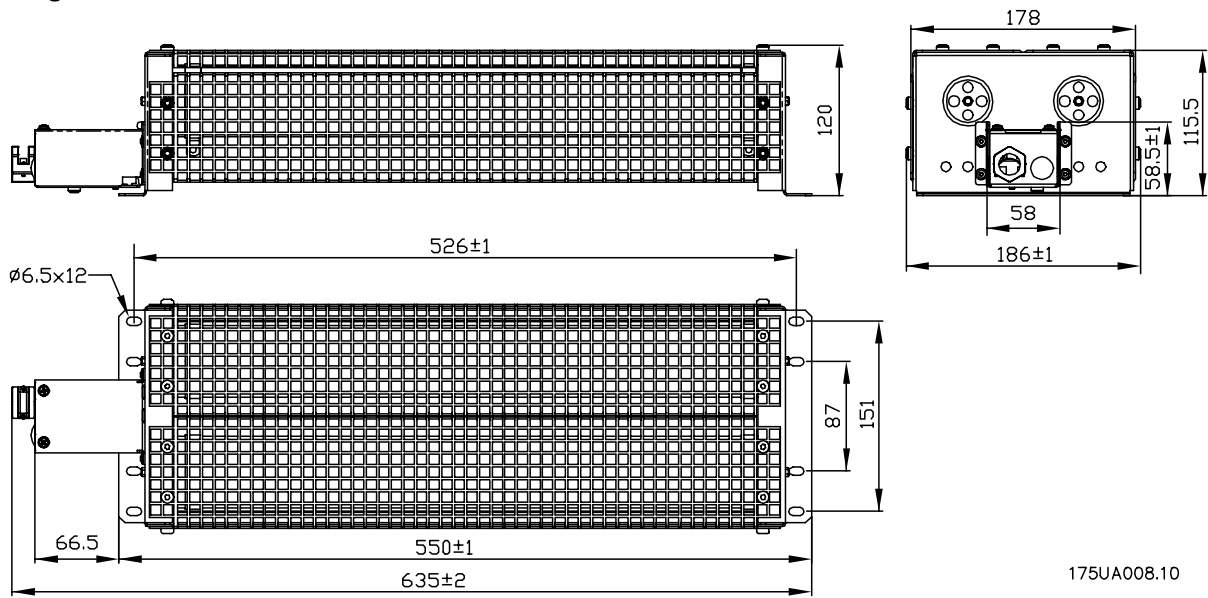

■ Drawing no. 9

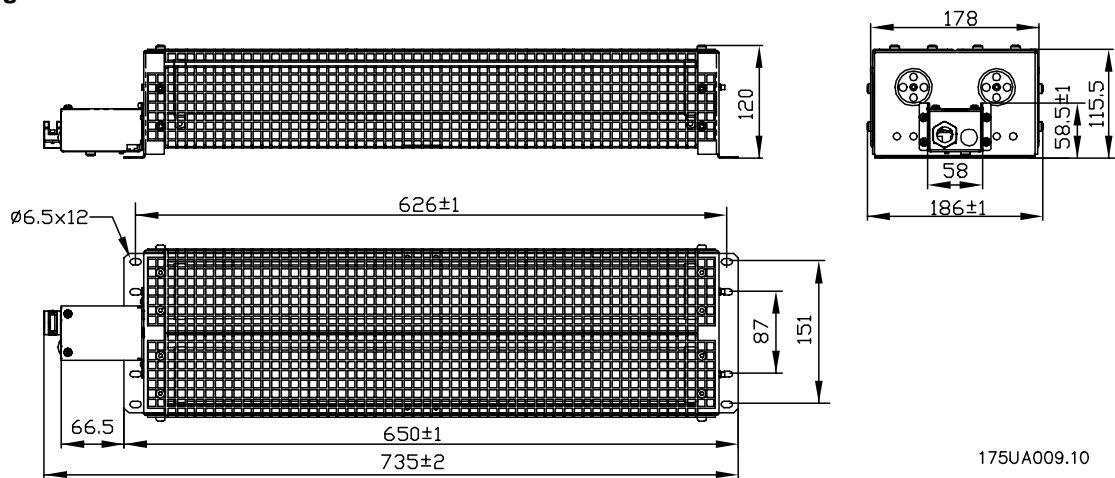

■ Drawing no. 10

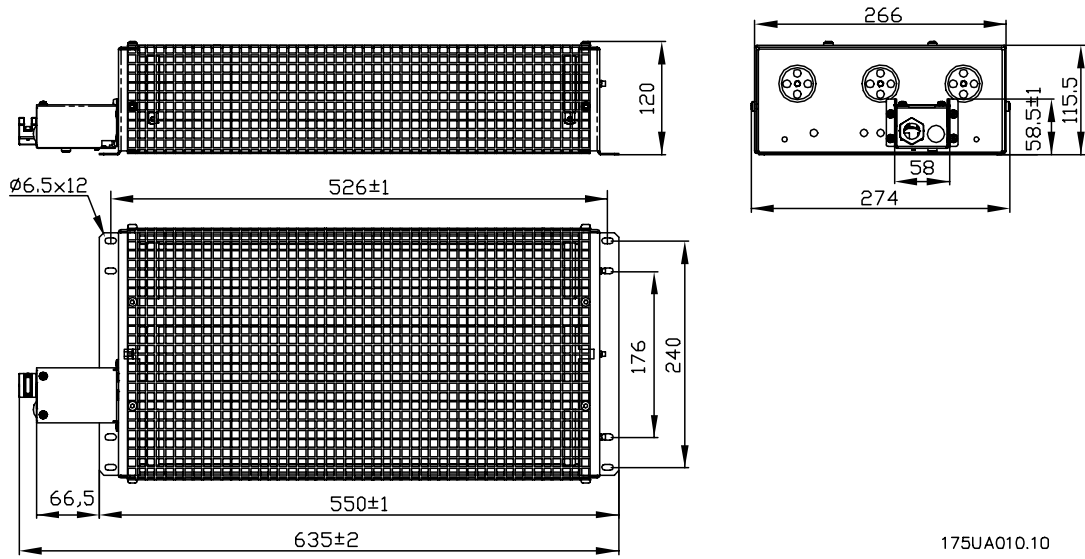

■ Drawing no. 11

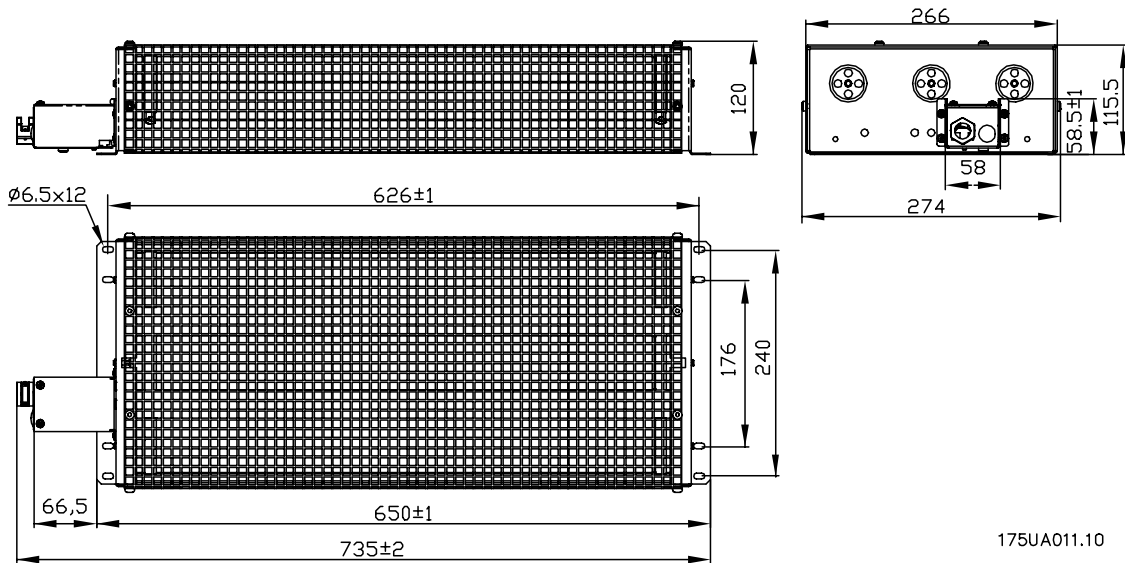

■ Drawing no. 12

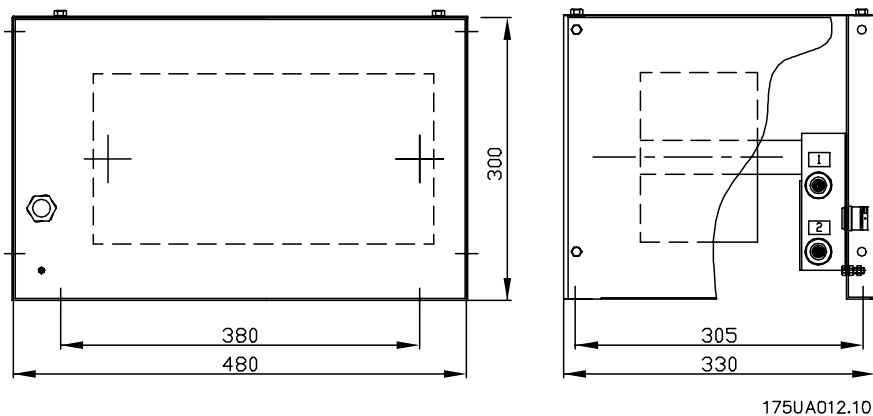

Drawings 1  
- 19

■ Drawing no. 13

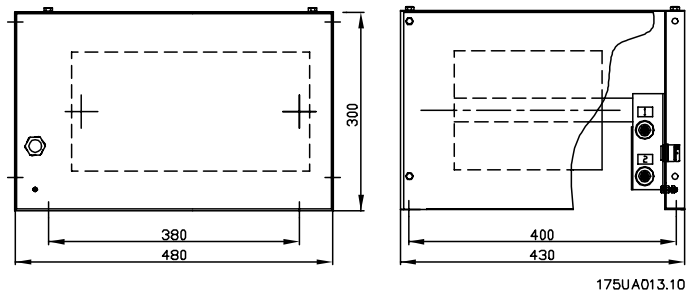

■ Drawing no. 14

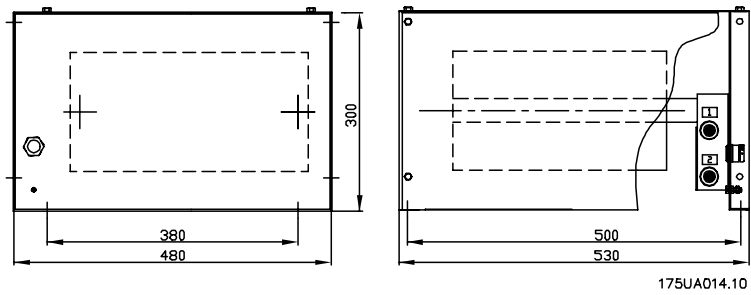

■ Drawing no. 15

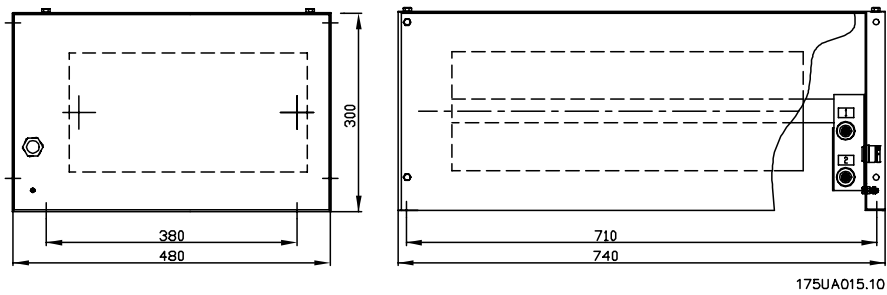

■ Drawing no. 16

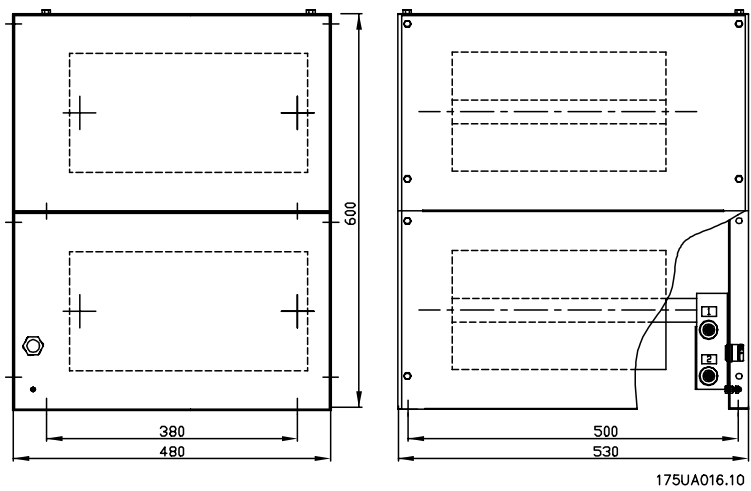

■ Drawing no. 17

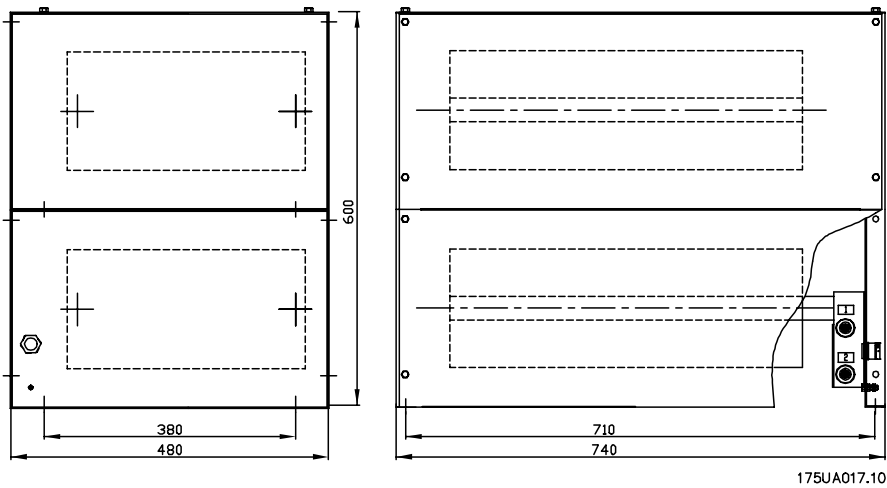

■ Drawing no. 18

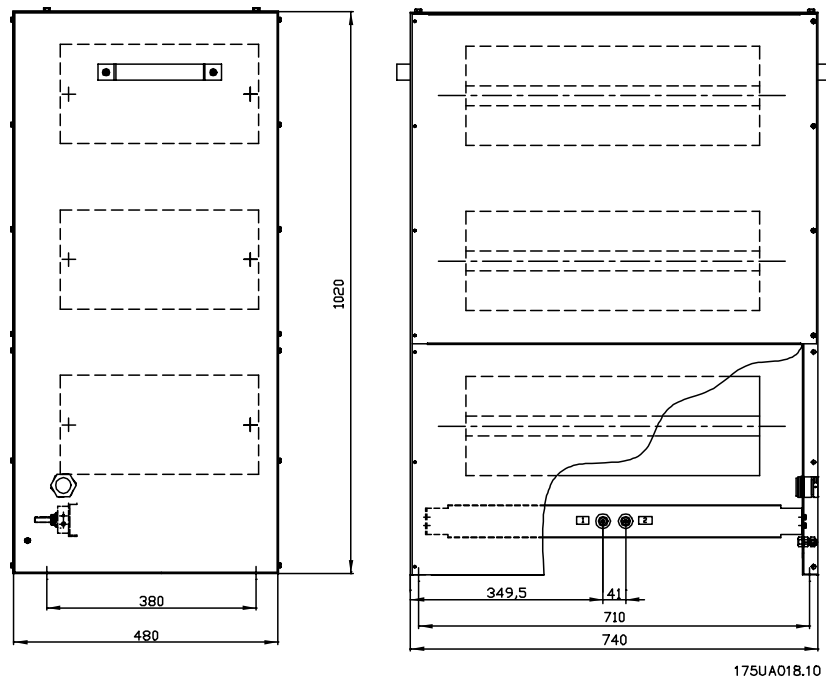

Drawings 1  
- 19

■ Drawing no. 19

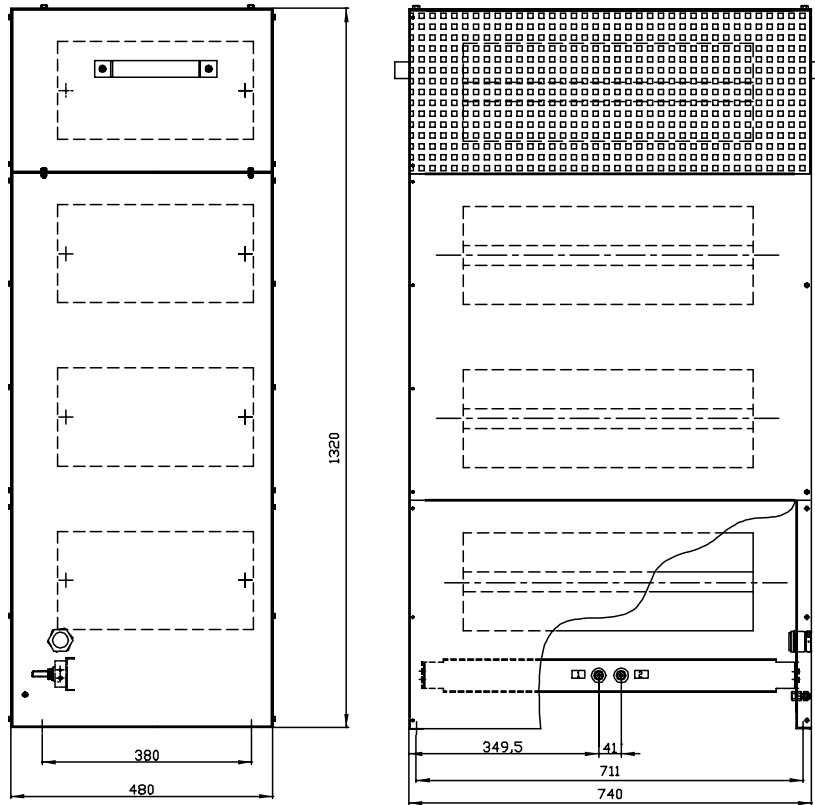

175UA019.10



VLT® 2800 / 5000 / 5000 FLUX / FCD 300



Instruction

VLT® frequency converters BAUER geared motors

Danfoss can accept no responsibility for possible errors in catalogues, brochures and other printed material. Danfoss reserves the right to alter its products without notice. This also applies to products already on order provided that such alterations can be made without subsequential changes being necessary in specifications already agreed. All trademarks in this material are property of the respective companies. Danfoss and the Danfoss logotype are trademarks of Danfoss A/S. All rights reserved.



VLT® 2800 / 5000 / 5000 FLUX / FCD 300



Instruction

Brake Resistor

