

SIEMENS

SIPART DR22

Controllers - Positioners -
Software

Supplement May 1999
to Catalog MP 31 · 1998

Supersedes:
Catalog MP 31 · 1998, Section 6

SIPART DR

DR22 Controllers
Input/Output module
3AO/3DI

6

Appendix

Conditions of sale and
delivery
Year 2000 compatibility

The products and systems described in this catalog are sold under application of a quality management system certified by DQS in accordance with DIN EN ISO 9001 (Certificate Registration No.: 19656-04). The DQS Certificate is recognized in all EQ Net countries (Reg. No.: 19656).



REG. NO. 19656-04

- NEW -
with extended
scope of functions

SIPART DR22 Controllers

6

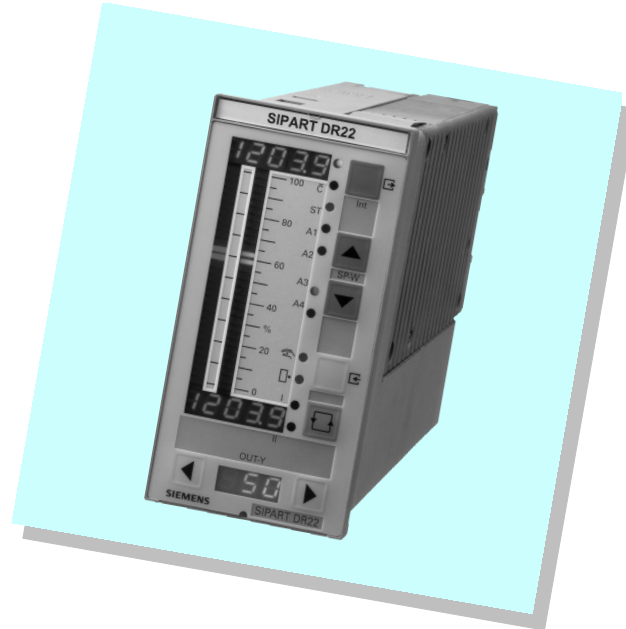

	Page
Description	6/2
Application	6/2
Design	6/2
Mode of operation	6/3
Configurable functions	6/6
Further configurable functions	6/13
Control and display functions	6/16
Function diagram	6/18
Technical data	6/22
Ordering data	6/24
Input/output modules for SIPART DR22	6/25
Overview applications	6/25
Module 3AO/3DI (6DR2802-8B)	6/26
Further modules see Catalog MP31 · 1998, Section 8	
Appendix	6/27

SIPART DR22 Controllers

6DR2210-

Description



Fig. 6/1 SIPART DR22 controller

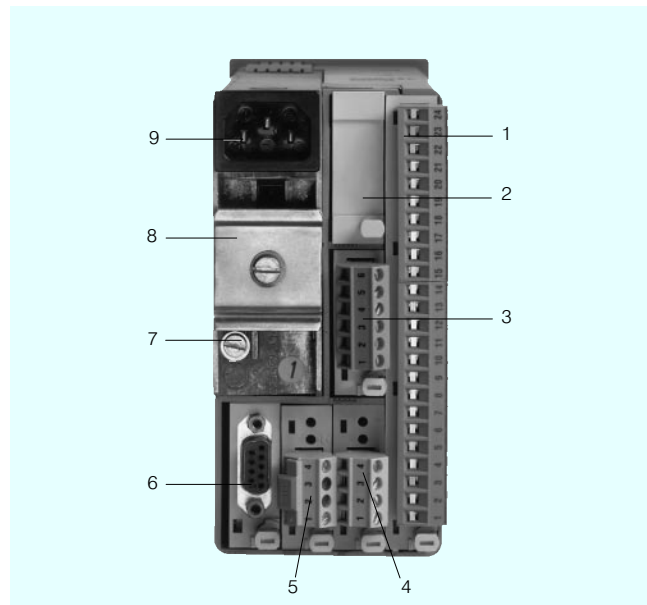

- 1 Slot 1, main circuit board
- 2 Slot 6, not fitted
- 3 Slot 5, fitted with module
- 4 Slot 2, not fitted
- 5 Slot 3, fitted with module
- 6 Slot 4, fitted with module
- 7 Earthing screw
- 8 Top-hat rail (included in delivery of relay modules)
- 9 Mains plug

Fig. 6/2 SIPART DR22 controller, rear view

Application

The SIPART DR22 process controller is a digital operating instrument with a "top class" performance. Within the internal program memory are a large number of functions for controlling processes, which can be simply retrieved by the user without any programming knowledge or accessories.

If required, function blocks for mathematical and logic functions can be easily added to the input connections, thus enabling optimum adaptation to more complex tasks.

The controller incorporates a versatile adaptation procedure which greatly simplifies commissioning, even of critical controlled systems. During this procedure, the controller automatically determines the optional parameters for stable control, even if the user has no preliminary knowledge of the controlled system's response. The adaptation procedure is suitable for controlled systems with recovery times and aperiodic transient responses. Even large dead times are taken into account.

The SIPART DR22 controller can be used as

- Fixed setpoint controller for one, two or three-component controls, optionally also with two setpoints
- DDC fixed setpoint controller for one, two or three-component controls
- SPC controller
- Slave controller (synchronization controller), optionally with local/remote switchover
- Fixed or controlled ratio controller with local/remote switchover
- Cascade controller (dual-loop controller)
- Ratio cascade controller (dual-loop controller)
- Override controller (dual-loop controller)
- Dual-loop controller with two independent control channels.

The universal flexibility is made possible by the extensive hardware of the instrument, which can easily be extended as required by a wide range of input/output modules (e. g. communication via a serial interface with a higher-level system or personal computer).

The SIPART DR22 controller has a large number of displays. Both the process variable and the setpoint are indicated on an analog and digital display. A further digital display is used to indicate the manipulated variable.

The SIPART DR22 controller can be used as a continuous controller with a current output or as a three-position step output for connection to electromotive drives without changing the hardware equipment. The split-range mode of the K controllers is configurable.

Design

The SIPART DR22 process controller is of modular design.

The standard controller comprises:

- Front module with controls and displays
- Main circuit board with CPU and terminal strips
- Plastic housing with a connecting board and the power pack.

The main circuit board has a 10-way and a 14-way plug-in screw terminal block, to which all inputs and outputs of the standard controller are connected. Five further slots can be equipped with optional modules if the number of inputs and outputs within the standard controller is insufficient for the application. Field signals are connected to the input/output modules on each module by a pluggable terminal strip or connector (serial interface SES).

Description

The standard controller comprises:

- 3 analog inputs for voltage (0/0.2 to 1 V or 0/2 to 10 V) or current (0/4 to 20 mA) signals.
The inputs are electronically isolated and have high common mode rejection.
- 4 digital inputs 0/24 V and 8 digital outputs 0/24 V, which can be used for various functions and can act in normal or inverted mode.
- 3 analog outputs, each with a current signal 0 to 20 mA or 4 to 20 mA, which can be used for all controller variables.
- A short-circuit proof L+ output (DC 24 V, 100 mA) for powering transmitters.

The power supply unit is in a completely enclosed metal housing.

Available versions:

- 6DR2210-4 for AC/DC 24 V power supply
- 6DR2210-5 for AC 230 V power supply, switchable to AC 115 V.

The tagging label and the scale can be replaced.

The number of inputs and outputs can be extended by supplementary modules.

Modules are available for:

- Current or voltage input (U/I)
- UNI module for TC/RTD/R/mV, also for mA and V with adapter plug; with electrical isolation
- Resistance input (potentiometer) (R)
- Analog outputs and digital inputs
- Digital inputs and outputs (DI/DO)
- Relay outputs (Rel)
- Serial interface (SES)
- PROFIBUS-DP module

Refer to the table "Overview: applications" on page 6/25 for configurations for expanding the functions.

Mode of operation

The SIPART DR22 controller is based on a modern microcontroller with CMOS technology.

The ROM contains a large number of complete functions for controlling process engineering plants. The user configures the controller according to the respective task by selecting the desired function using the so-called configuring switches (cf. page 6/20). In order to solve more complex control tasks, the user can reconfigure the standard connections of the analog inputs and use other mathematical or analog logic functions in their place (cf. page 6/5).

Neither a special programming knowledge or a programming unit are required to configure the controller.

The application program produced in this manner is stored in non-volatile memory and thus protected in the event of a power failure. A back-up battery is not required. This user program memory can be replaced.

The SIPART DR22 controller can be configured as a P, PD, PI or PID controller.

Analog input connections

■ Fixed input range

The analog inputs AE1 and AE11 can be freely-assigned to the function inputs FE1 to FE12 when configuring the controller. These function inputs then form the analog input channels for the various types of controller.

The significance of the function inputs FE1 to FE12 is determined by the configured controller type or the output structure of the controller.

Each analog input has a first order filter with a selectable time constant to suppress external noise and a selectable square root extractor.

A function generator (linearizer) with 13 vertices for linearizing input signals can be connected to the function inputs FE1 and FE3.

(The two linearizers can be freely-assigned in "Freely-connectable input range".)

■ Freely-connectable input range

In this operating mode, additional arithmetic and logic functions can be inserted between the data sources (analog inputs, parameters, constants) and the data sinks (FE1 to FE12) (Fig. 6/3). Insertion is carried out – as with the further configuring of the controller – via the front module according to a menu-based question-and-answer procedure or via the interface.

The following data sources/sinks are present in the "Freely-connectable input range":

Data sources

Designation	Explanation
AE1.A to AEb.A	Analog signal input (filter/square-root)
P01 to P15	Parameters (setting in onPA)
-1.0 to +1.0	Constants
BE01 to BE09	Digital inputs BE1 to BE9
AE1 _h to AE5 _h	Single message for sensor breakage (alarm)
AE _h	Group signal for sensor breakage (alarm)
A1 to A4	Alarms A1 to A4
Int1 and Int2	Status message for internal operating mode of controller 1 / controller 2
SPI 1 and SPI 2	Internal setpoint for controller 1 and controller 2
SP1 and SP2	Effective setpoint for controller 1 and controller 2
Y1 and Y2	Manipulated variable Y for controller 1 and controller 2 (K controller)
SAA1 to SAA4	Serial analog input (can only be written via interface)
MA _h .4 to no _h .4 (see Fig. 6/3).	Outputs of the function blocks defined in FdEF (non-defined blocks are suppressed)

Description

Data sinks

Designation	Explanation
FE01 to FE08	Function inputs "Analog values" for the configured controller or the hardware outputs of the controller
FE09 to FE12	Function inputs "Analog values" for the configured controller or analog/binary signals for the hardware outputs of the controller
ME_1 to no_3 (see Fig. 6/3)	Inputs of the function blocks defined in FdEF (non-defined blocks are suppressed)

The following functions can be inserted (Fig. 6/3):

- 6 arithmetic blocks (Ar1 to Ar6)
Each of these 6 arithmetic blocks can be occupied as required by the 4 fundamental arithmetic operations or a combination of them.
- 2 function generators (Fu1 and Fu2)
Each of these two function generators (linearizers) assigns an output variable A in the range from -199.9 to $+199.9$ % to each value of its input variable E in the range from -10 to $+110$ % using a function entered by the user; $A = f(E)$.
The function is entered via 13 vertices for the input signal from -10 to $+110$ % at intervals of 10 %. Parabolas are generated between the vertices by means of the calculation program and are combined tangentially at the vertices so that a continuous function results.
- 3 function blocks "Max. selection" (MA1/MA2/MA3)
A maximum selection from 2 or 3 input variables can be made in each of these 3 function blocks. The function blocks can also be used for minimum limiting.
- 3 function blocks "Min. selection" (Mi1/Mi2/Mi3)
A minimum selection from 2 or 3 input variables can be made in each of these 3 function blocks. The function blocks can also be used for minimum limiting.
- Correction computer (rE1)
The correction computer is used to calculate the flow of gases using the differential pressure p flow measuring principle, correcting for fluctuations in pressure and temperature. Both mass flows and volume flows can be corrected when referred to the process operating conditions and volume flows also when referred to standard conditions (i. e. standard parameters). However, the medium must be in a pure phase. In other words, gas separation must not take place. The following relationship is applicable for the output A :

$$A = \sqrt{\Delta p} \cdot \sqrt{f(E_2, E_3)}$$

$$f(E_2, E_3) = \frac{(P_E - P_A) E_2 + P_A}{(t_E - t_A) E_3 + t_A}$$

The measuring ranges are standardized to the formula by using the parameters t_A , t_E , P_A and P_E . t_A and P_A are adjustable from 0.01 to 1.000 , t_E and P_E from 1.000 to 99.99 .

- 5 changeover switches for analog values (AS1 to AS5)
- 2 comparators with selectable hysteresis (Co1, Co2)
- 2 logic functions "NAND" (nA1, nA2)
- 2 logic functions "NOR" (no1, no2)

Analog output connections

The 9 analog outputs of the SIPART DR22 controller (3 on standard controller, 6 on optional module) output a current signal of 0 to 20 mA or 4 to 20 mA.

The outputs are not assigned to fixed variables. When configuring a controller they are assigned any internal controller variable that is required externally. Thus a split-range output is also possible.

When the optional y -hold module is inserted in analog output, the output is permanently assigned to the manipulated variable y .

Digital input and output connections

The standard device has 4 digital inputs BE1 to BE4 as well as 8 digital outputs BA1 to BA8. When configuring the controller, the digital functions required for the respective application are assigned to these inputs and outputs. The number of digital inputs and outputs can be increased by using additional optional modules if the number in the basic device is insufficient. Slots 5 and 6 at the rear of the controller can be used for this purpose. Up to 14 digital inputs or up to 16 digital outputs are possible, depending on the equipment installed with options.

The digital inputs and outputs of the device are non-floating.

The digital outputs are active and provide a 24 V DC signal with a loading capacity of up to 50 mA per output.

Floating outputs are available, if a relay module with two digital outputs is used as an option. An interface relay module can also be snapped onto a top-hat rail on the rear of the controller. This additional module has either two or four relays each with 1 changeover contact rated at AC 250 V, 8 A, which are energized by the controller's digital outputs.

Description

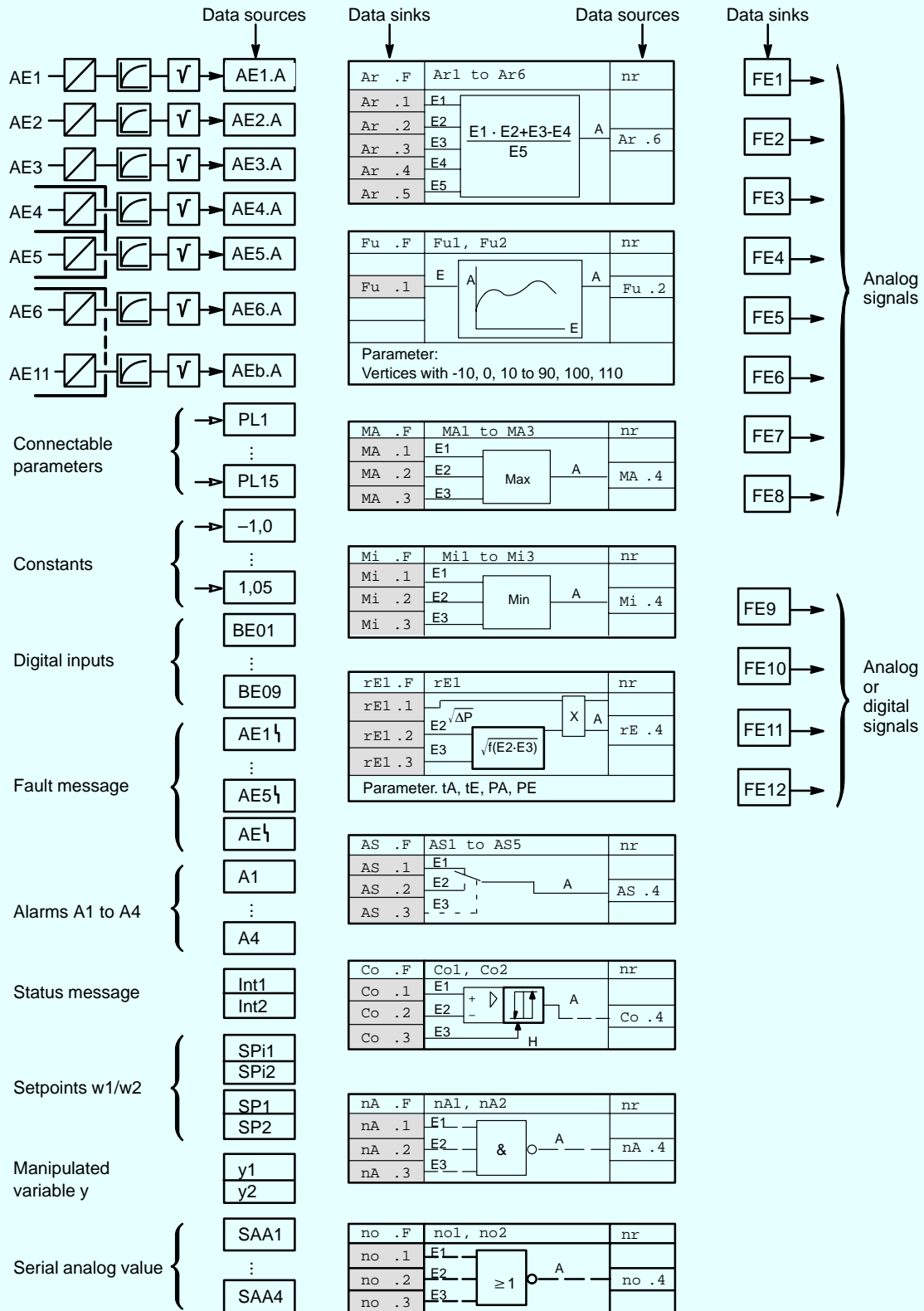

Fig. 6/3 Insertion of additional functions for the freely connectable input range

SIPART DR22 Controllers

6DR2210-

Description

■ Digital inputs

The digital inputs have the following functions:

- CB I/II** Computer status (Controller 1/Controller 2)
Depending on the type of controller configured, this digital input together with the local/remote pushbutton either switches to a different setpoint, also SPC mode or it begins in the DDC mode. When the controller is being used in SPC or DDC mode this input indicates the central computer's status.
- He I/II** Remote manual (Controller 1/Controller 2)
This signal blocks the controller output and enables direct manual adjustment of the manipulated variable from the front panel.
- N I/II** Tracking (Controller 1/Controller 2)
This signal causes the output of the K controller and the three-position step controller with external position feedback to track the signal y_N .
- Si I/II** Safety mode (Controller 1/Controller 2)
The manipulated variable assumes the parameterized safety value in the case of K controllers and three-position step controllers with external position feedback. In the case of three-position step controllers with internal generation of the position, the manipulated variable moves in a defined manner towards 0 or 100 %.
- tS I/II** Setpoint ramp cut-off (Controller 1/Controller 2)
- WSL I/II** External setpoint switchover analog or via SES (Controller 1/Controller 2)
- BLB** Blocking of operation
- BLS** Blocking of configuring
- BLPS** Blocking of parameterization and configuring
- P I** P mode, controller I
- P II** P mode, controller II
- PAU** Parameter switchover / The parameter set I of the single controller can be switched over to the parameter set II with this digital signal.
- $\pm \Delta w$ Incremental setpoint adjustment
- $\pm \Delta y$ Incremental manipulated variable adjustment
- $\pm \Delta yBL$ Direction-dependent blocking of manipulated variable I/II (Controller 1/Controller 2)

■ Digital outputs

The digital outputs have the following functions:

- RB I/II** No computer readiness (Controller 1/Controller 2)
- RC I/II** No computer mode (Controller 1/Controller 2)
- H I/II** Manual mode (Controller 1/Controller 2)
- N I/II** Tracking mode (Controller 1/Controller 2)
- A1/A2** Alarms 1 and 2
- A3/A4** Alarms 3 and 4
- MUF** Transmitter fault
- Int I/II** Local mode (slave controller) (Controller 1/Controller 2)
- FE9 to FE12** Function inputs (data sinks) with optional connections in input range.

The manipulated variable outputs $\pm \Delta y$ of a three-position step controller are always assigned to digital outputs BA7 and BA8. The manipulated variable outputs $\pm \Delta y$ are set to BA5 and BA6 when controller 2 of the dual-loop controller is configured as step controller. These digital outputs are then not available for optional assignment.

Displays

The SIPART DR22 controller has extensive display facilities. Both the setpoint and the process variable have bargraph and digital indication.

The 2 analog displays consist of vertical LED bargraphs. One or two LED's light up, the center of the illuminated field indicates the process variable. Comparison between the process variable and the setpoint is easy since both displays are side by side. Both displays provides a dynamic trend indication.

The process variable and setpoint digital displays can be scaled in engineering units or percentages. The process variable displays are red and the setpoint green. The associated pushbutton controls are also colored the same for simplified operation.

When configured as a dual-loop controller (cascade and override controls 2 independent control loops) the displays are switched from one loop to the other by the pushbutton controller I/controller II. This ensures that the display is clear and informative avoiding confusion.

A yellow three-digit display indicates the manipulated variable. This is always indicated in percent. The associated pushbutton controls are also yellow.

Status flags and alarms are also displayed on the front panel with 11 LEDs with a fixed assignment.

The display modes described refer to the process operation mode of the controller. Some of these displays have different functions in the selection and configuring modes (cf. page 6/16).

Configurable functions

Standard configurations used for process control applications are stored in the EPROM of the SIPART DR22 controller and can be easily selected. In conjunction with the optional connections of the input range, this device may be used in all closed-loop control tasks of the process engineering.

The standard configurations possible are shown below using schematic diagrams and are described in brief. Only the most important elements are detailed to avoid confusion. Other configuring possibilities, valid for all controller types, are described page 6/13.

The factors and constants c_1 to c_9 shown in the following Figs. as well as the setpoint ramp tS are adjusted in the parameter mode.

A disturbance variable can be applied to the manipulated variable via function input FE4 or FE7 either in dynamic mode via the D-element or in static mode directly to the output.

The function inputs are only shown in the Figs. if they have a fundamental function in the associated type of controller.

Description

■ Configuring switch S1 = 0

Fixed setpoint controller with one or two independent setpoints as a single-component, two-component or three-component controller

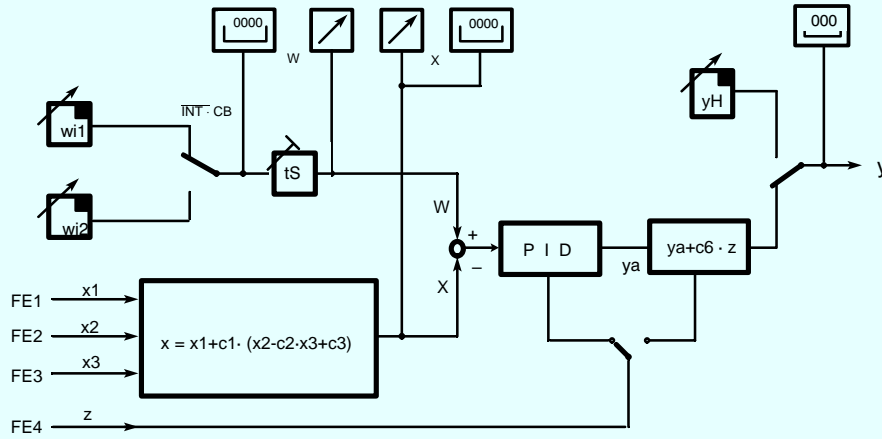

Fig. 6/4 Fixed setpoint controller with 2 independent setpoints, function diagram

As shown in Fig. 6/4 the controller can process logic operations on the analog input signals from the function inputs FE1, FE2 and FE3 as the controlled variable and can therefore be used as a single-component, two-component or three-component controller.

Two setpoints w_{i1} and w_{i2} can be adjusted independently on the front of the controller and selected using the local/remote push-

button (2, Fig. 6/14) or the digital signal CB. The switchover between setpoint 1 and setpoint 2 either has a sudden jump or can be made to ramp up or down over a time period dependent on the setting of parameter tS . Since the switchover function can be blocked, this type of configuration is also used as a fixed setpoint controller with one setpoint.

■ Configuring switch S1 = 1

Fixed setpoint controller with two dependent setpoints as a single-component, two-component or three-component controller

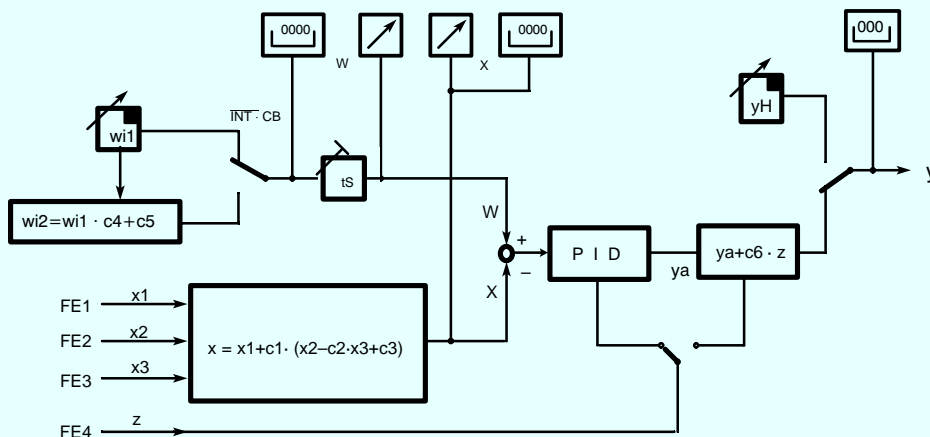

Fig. 6/5 Fixed setpoint controller with two dependent setpoints, function diagram

The functions of this controller are shown in Fig. 6/5. The controller can also process logic operations on the analog input signals from the function inputs FE1, FE2 and FE3 as the controlled variable. It can therefore be used as a single-component, two-component or three-component controller.

The setpoint w_{i1} can be adjusted on the front of the controller. A second setpoint can be derived according to the equation

$$w_{i2} = w_{i1} \cdot c_4 + c_5$$

w_{i2} then changes automatically if w_{i1} is changed. It is possible to switch between these 2 setpoints using the local/remote pushbutton (2, Fig. 6/14) or the CB signal. The switchover has a sudden jump or can be made to ramp up or down over a time period dependent on the setting of parameter tS .

SIPART DR22 Controllers

6DR2210-

Description

- Configuring switch S1 = 2

DDC fixed setpoint controller as a single-component, two-component or three-component controller

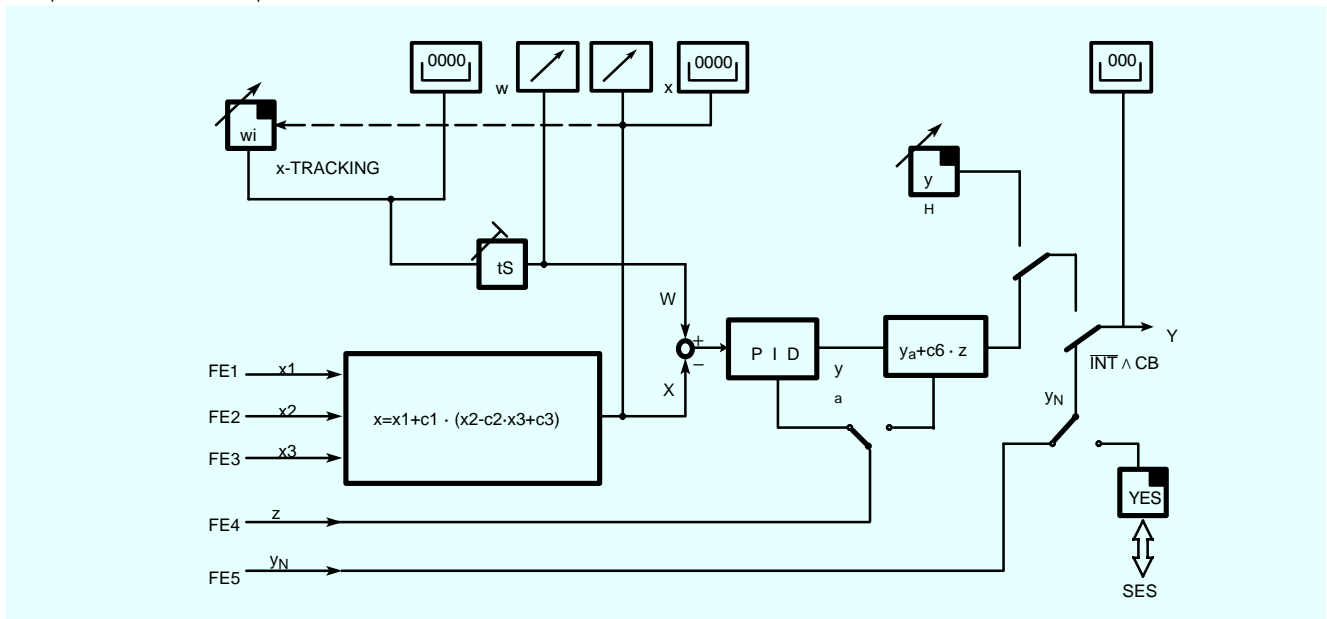

Fig. 6/6 DDC fixed setpoint controller, function diagram

With DDC control, the control function is performed directly by a process computer. The control loops are protected by parallel compact controllers in the event of a computer failure.

The controller is on standby during DDC mode. It receives the manipulated variable from the process computer and tracks this with its own manipulated variable. This ensures that the control is continued in a bumpless manner when the process computer develops a fault. The switchover criterion is the CB signal or the local/remote pushbutton (2, Fig. 6/14). The controller then works autonomous in both cases.

The controller can process mathematical and logic operations on the analog signal from the function inputs FE1, FE2 and FE3. It can therefore be used as a single-component, two-component or three-component controller.

The setpoint is set as w_i on the front of the controller. The negative deviation is set to zero in DDC mode by x-tracking so that the switchover is drift-free as well as bumpless.

The SIPART DR22 controller can be connected to the process computer with a parallel connection via its hardware interfaces and outputs or also via a serial data bus.

6

¹⁾ DDC Direct Digital Control.

Description

- Configuring switch S1 = 3, slave controller (synchronization controller) with local/remote switchover and SPC controller

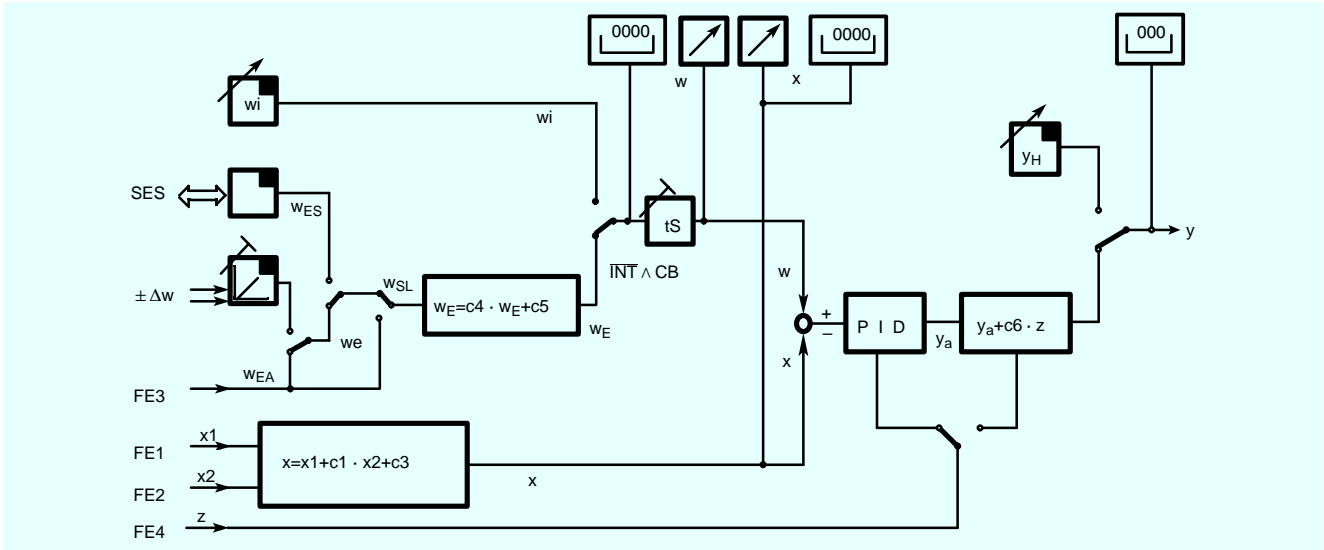

Fig. 6/7 Slave controller (synchronization controller), function diagram

This mode is used for SPC¹⁾ operation or for follow-up control. The controller can process mathematical and logic operations from the function inputs FE1 and FE2.

The external setpoint can be input to the controller as an analog signal via function input FE3 or incrementally via two digital inputs ±Δw, or via the serial interface. It can be biased for synchronization control by the factor c₄ or offset by a constant c₅.

With an incremental setpoint the setpoint ramp tS determines the rate of change.

The remote setpoint switchover is by either using the local/remote pushbutton (2, Fig. 6/14) or the CB signal. Following loss of the CB signal, the controller continues to operate with the last setpoint or uses the parameterized safety setpoint depending on the mode configured.

- Configuring switch S1 = 4, fixed ratio controller or controlled ratio controller with local/remote switchover

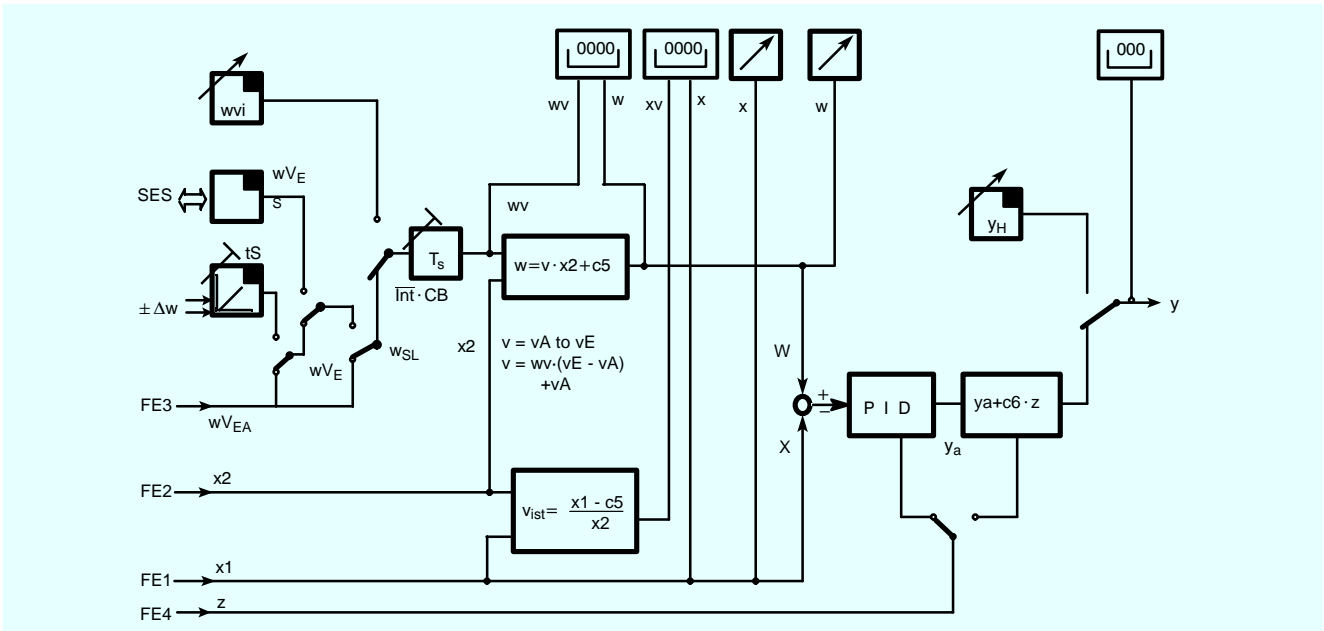

Fig. 6/8 Fixed or controlled ratio controller, function diagram

The master process variable is the signal x₂ of function input FE2. The controlled process variable x₁ is input via FE1. The setpoint for this type of controller is not an absolute value but is the setpoint ratio between the controlled process variable and the master process variable as the factor v (w_v).

The relationship is as follows:

$$v = \frac{x_1 - c_5}{x_2}$$

1) SPC Setpoint Control.

Description

The range of adjustment for the ratio factor $v = v_A$ to v_E is between 0.0 and 9.999 and is defined in parameter mode. Constant c_5 can be used as an offset.

The setpoint ratio v and the actual value v_{actual} are indicated on the four-digit displays. The controlled variable x and the effective setpoint w biased by the ratio factor are indicated on the analog displays. The controlled variable x and the effective

setpoint w can also be indicated on the digital displays in the engineering range.

The ratio factor can be input remotely. The switchover conditions correspond to those of the slave controller. Since the switchover function can also be blocked, the controller can also be used as a fixed ratio controller with this configuration.

- Configuring switch S1 = 5, cascade controller

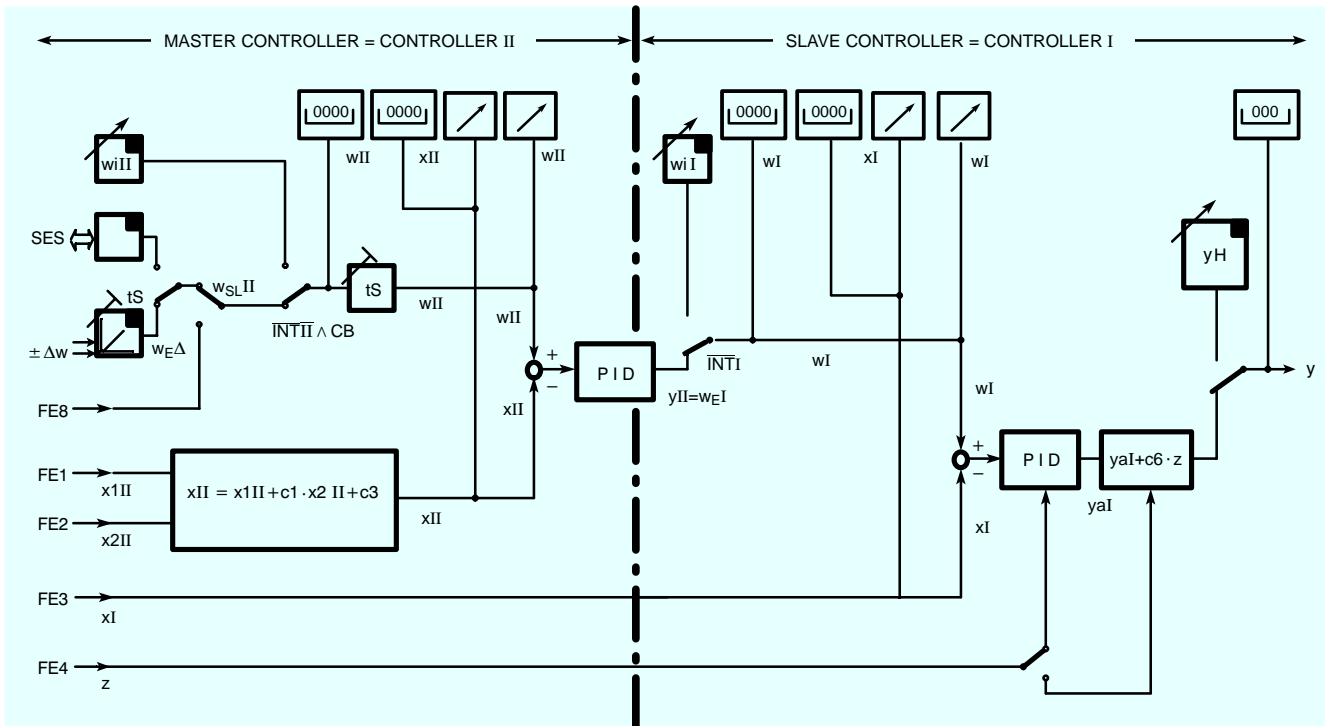

Fig. 6/9 Cascade controller, function diagram

This type of controller contains both the master controller (controller II) and the slave controller (controller I) of the cascade. The displays as well as the setpoint adjusters and the local/remote pushbutton of the controller have dual functions. Operation is clear and simple:

The controller selector (12, Fig. 6/14) including LEDs is used to switch between controller I and controller II. The displays as well as the pushbutton functions mentioned are assigned to the controller selected. In the Fig. 6/9, the corresponding functions are identified in each case by the suffixes I and II.

- Master controller (controller II)

This controller processes mathematical and logic operations on the input variables from FE1 and FE2. The controller operates as a fixed setpoint controller with the facility for a remote setpoint, either as analog signal (FE8), incrementally via two digital inputs $\pm \Delta w$ or via the serial interface. The switchover is then made using the local/remote pushbutton INT II or the CB signal.

The master controller operates with parameter set II.

- Slave controller (controller I)

The slave controller receives the manipulated variable of the master controller as its "remote" setpoint. Switching over to a local setpoint (cancellation of the cascade) is achieved by pressing the local/remote pushbutton INT I. The output of the master controller is then made to track the setpoint of the slave controller, and the x-tracking can be configured for both devices, ensuring that connection of the cascade is bumpless and drift-free.

The slave controller can be set to manual mode at any time using the M/A pushbutton. This pushbutton and the associated adjustment pushbuttons and the manipulated variable display are not switched over to the master controller.

The slave controller operates with parameter set I.

Description

- Configuring switch S1 = 6, cascaded ratio controller

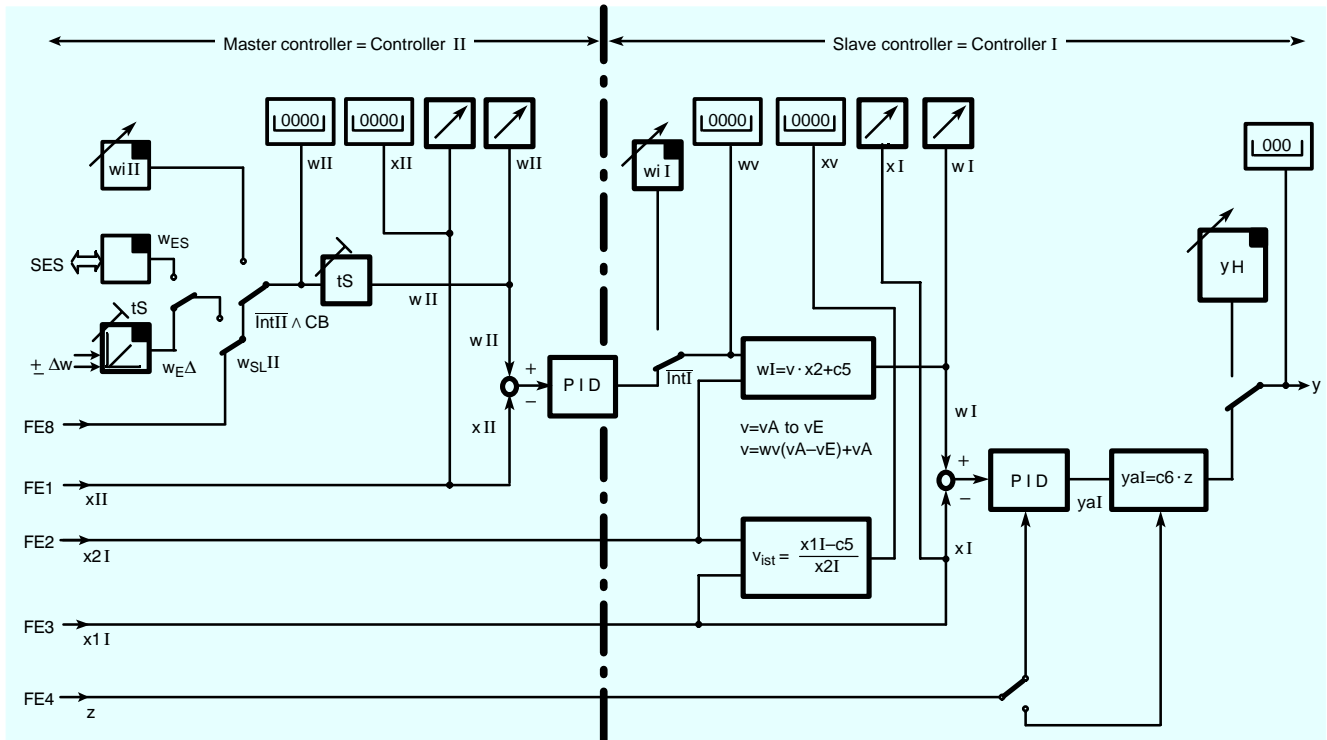

Fig. 6/10 Cascaded ratio controller, function diagram

With this configuration the device comprises the master controller (controller II) and the slave ratio controller (controller I). The displays, setpoint adjusters and local/remote pushbuttons also have dual functions.

The selector (12, Fig. 6/14) including LEDs is used to switch between controller I and controller II and to assign the displays and the pushbutton functions mentioned to the controller selected. The corresponding functions are identified in Fig. 6/10 by the suffixes I and II.

- Master controller (controller II)

The controlled process variable is applied to function input FE1. The controller operates as a fixed setpoint controller with the facility for a remote incremental input of the setpoint via two digital inputs or via the serial interface. The switchover is made using the local/remote pushbutton INT II or the CB signal.

The master controller operates with parameter set II.

- Ratio controller (controller I)

The command process variable is applied to this controller via function input FE2, the controlled process variable via input FE3. The "remote" setpoint for the controller is the manipulated variable of the master controller which is the setpoint ratio between the controlled process variable and the command process variable as a ratio v (w_v), where

$$v = \frac{x_1 - c_5}{x_2}$$

The range of adjustment for the ratio $v = v_A$ to v_E is between 0.0 and 9.999 and is defined in parameter mode.

The setpoint ratio v and the actual ratio v_{actual} are output on the four-digit displays. The controlled variable x and the effective setpoint w weighted by the ratio factor are output on the analog displays. The controlled process variable x_I and the effective setpoint w_I can be displayed on the digital indicators in the engineering range. Switching over to the local setpoint, and thus cancellation of the cascade is made using the local/remote pushbutton I (12, Fig. 6/14). The output of the master controller is made to track the setpoint of the ratio controller. x -tracking can be configured. This ensures that connection of the ratio cascade is bumpless and drift-free.

The ratio controller can be switched to manual mode at any time using the M/A pushbutton. This pushbutton, the associated adjustment pushbutton and the manipulated variable display are not switched over to the master controller.

The ratio controller operates with parameter set I.

SIPART DR22 Controllers

6DR2210-

Description

- Configuring switch S1 = 7/8

Override controller with maximum of y, Override controller with minimum of y

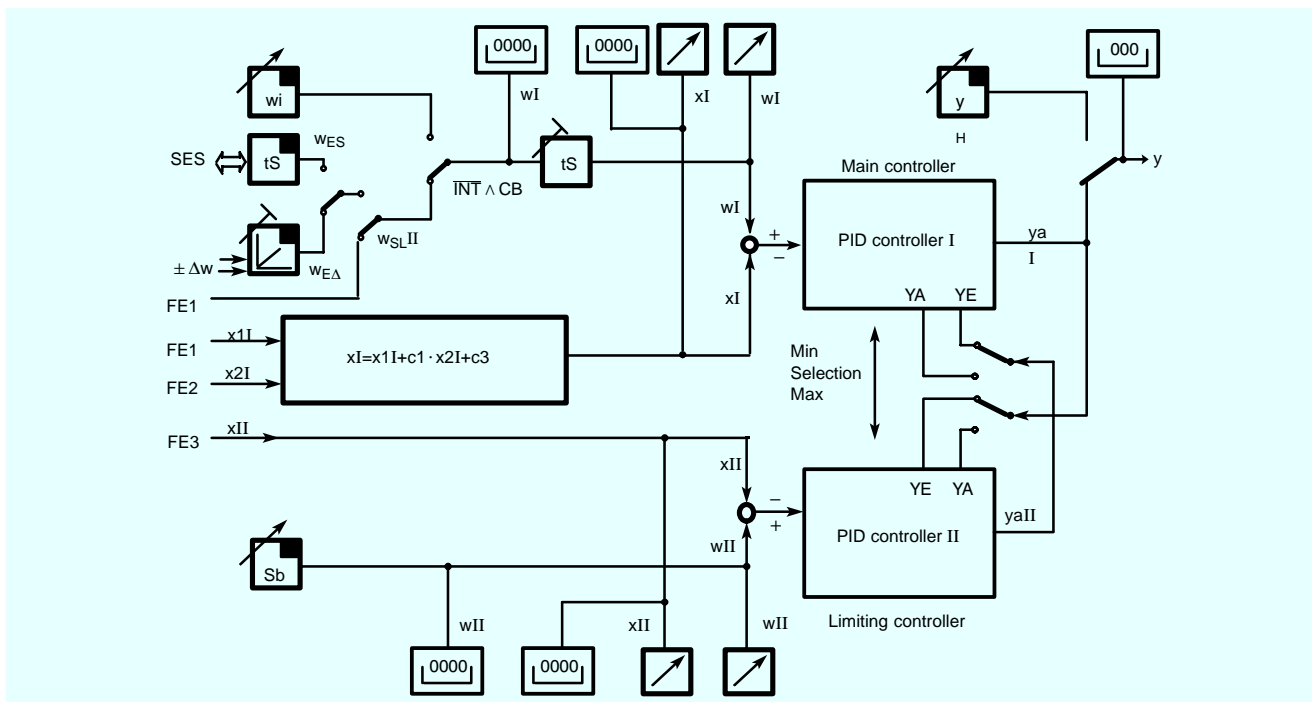

Fig. 6/11 Override controller with maximum/minimum limiting of y, function diagram

The override controller's function is to control a process variable without a second process variable exceeding a defined value. The two process variables are physically dependent on one another and are changed by the same final control element.

For example, the core temperature in a reactor is to be controlled without the jacket temperature exceeding or falling short of a certain value. For this task 2 controllers should be able to influence the final control element. Either the larger or the smaller of the two manipulated variables must be effective. The manipulated variable signal is selected in many cases using an extreme-value selector connected in series with the controller. However, this solution suffers from dynamic problems as a result of integral saturation of the controller not involved in the intervention.

This disadvantage is overcome in configurable controllers because the selection is made by mutual control of the manipulated variable limits and not by an extreme-value selection circuit. The maximum limiting is achieved by controlling the lower limit y_A and the minimum limiting by controlling the upper limit y_E . These parameters are the absolute manipulated variable limits in automatic mode. The mutual control can only take place up to this limit. The parameters y_A and y_E are adjusted in the parameter set of the main controller (controller I). The corresponding parameters of the limiting controller (controller II) are automatically adjusted.

In manual, tracking, safety or blocking mode, both controllers track the effective manipulated variable y. Switching over of the display I or II is carried out manually. The M/A switchover and the manipulated variable display are the same for both controllers.

- Main controller (controller I)

The controller can process mathematical and logical operations on the input variables from FE1 and FE2 as the controlled variable. The main controller is a fixed setpoint controller with the facility for remote input of the setpoint.

The switchover is then made using the local/remote pushbutton or the CB signal. The main controller operates with parameter set I.

- Limiting controller (controller II)

The controlled variable is applied to the limiting controller via function input FE3. The limiting setpoint S_b is set as a parameter.

- Configuring switch S1 = 9

Process variable display

With this configuration the SIPART DR22 controller does not act as a controller. The red digital and analog displays are connected in parallel to the function input FE1.

The green digital and analog displays are connected in parallel to the function input FE3.

The yellow digital display can be controlled via the function input FE6.

The limit monitors A1, A2, A3 and A4 can be assigned to the three function inputs already mentioned.

- Configuring switch S1 = 10

This fixed setpoint controller is specially designed for the coupling to the control system. It is largely based on the fixed setpoint controller with S1 = 0 (Fig. 6/4). Since the controller only operates with an internal setpoint w_{f1} , the signals INT and CB are available via the serial interface SES for blocking control system operations.

- Configuring switch S1 = 11

This follow-up controller is specially designed for the coupling to the control system. It is largely based on the follow-up controller with S1 = 3 (Fig. 6/7). Since the controller only operates with an external setpoint w_E , the signals INT and CB are available via the serial interface SES for blocking control system operations. The limiting controller operates with parameter set II.

Description

- Configuring switch S1 = 12

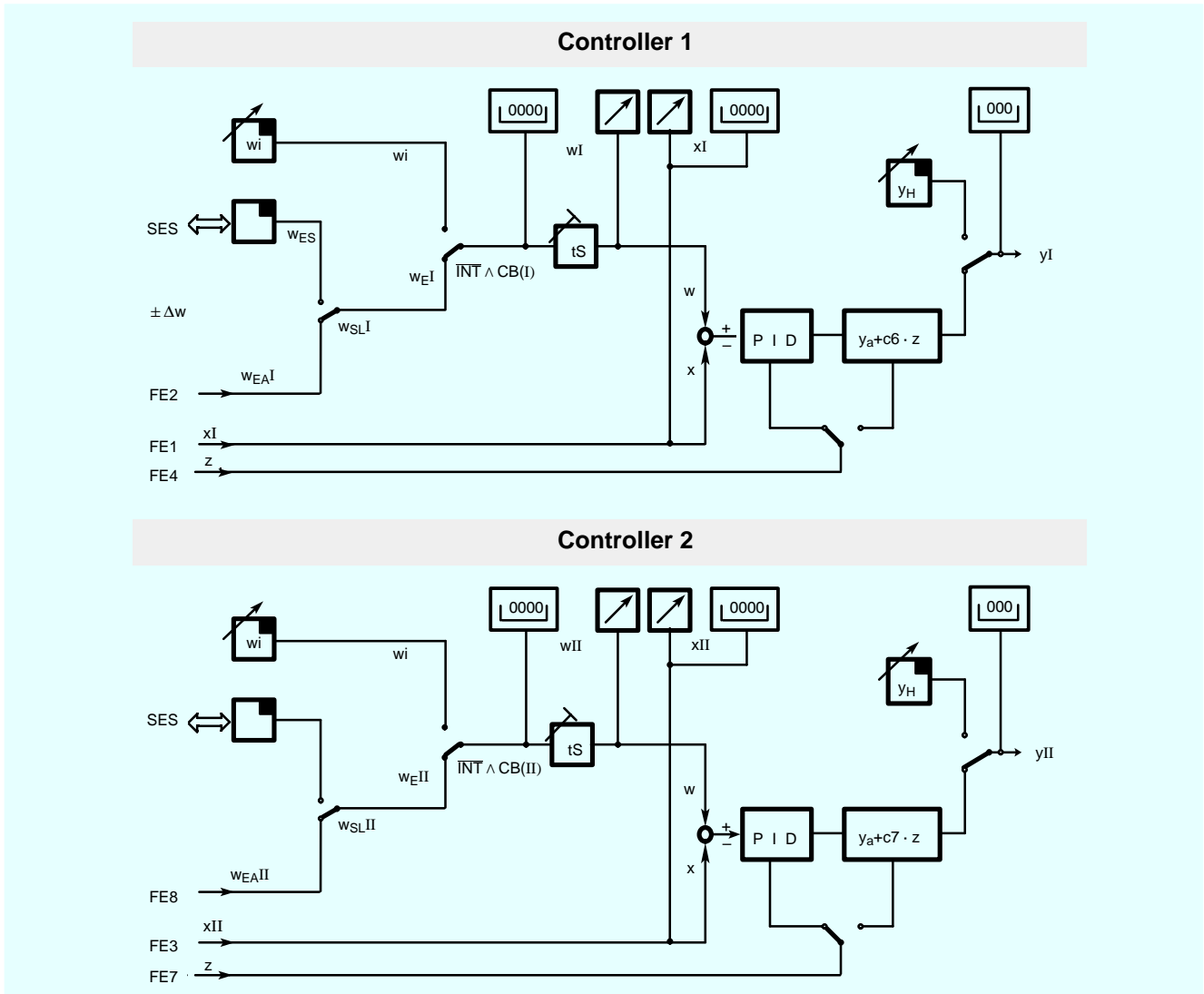

Fig. 6/12 Dual loop controller

When configuring as a dual-loop controller, the SIPART DR22 provides two completely independent control channels (PID). For operation and monitoring, the process operation level can be switched over for the display of controller I and controller II (x, w, y and the input keys).

The LEDs for the alarms A1, A2, A3 and A4 are not switched over at the same time. The alarms can be assigned to the various controlled variables of controller I and controller II.

Each control channel can be operated with an internal setpoint (fixed setpoint controller) or with an external setpoint (follow-up controller). Switching between the internal or external setpoint is possible using the front panel controls or a digital input (CB signal) providing this function has been enabled. The external setpoint is defined via the interface or an analog signal (switching over with binary signal w_{SL}).

The output structure can be selected independently as a K or S controller for each control channel.

Further configurable functions that enhance the flexibility and the operational safety of the SIPART DR22 controller

- Display in engineering units and linearization of process variables

The process variables (controlled variable x and command variable w) indicated on the two $4\frac{1}{2}$ -digit displays can be scaled in percentages or engineering units. The start-of-scale value, the full-scale value and the position of the decimal point of the displays are set as parameters.

A non-linear input variable must be linearized before it can be indicated. The standard input connections contain two function generators (linearizers).

- Transmitter monitoring

The analog inputs can be monitored for full-scale or start-of-scale violations of the signals ($< -3\%$ or $> +103\%$). The inputs to be monitored are selected using the configuring switches. In the event of a violation, a message appears - selective for the inputs AE1 to AE5 - on the four-digit display, indicating the faulty input signal. A common alarm is signalled via the digital output MUF.

Description

In addition, it is also possible to configure automatic switchover to manual mode, starting with the last manipulated variable or a safety manipulated variable.

The fault message can be acknowledged using the pushbutton (12, Fig. 6/14).

■ Setpoint ramp, setpoint limiting and x-tracking

In addition to the ramp function, it is possible to limit the range in which the setpoint or ratio setpoint can be adjusted by the parameters SA and SE. Both the setpoint ramp and the setpoint limits are effective with local or remote setpoints.

It is possible to configure x-tracking. In manual, tracking and DDC mode as well as with the safety manipulated variable, the setpoint w is made to track the controlled variable x so that a deviation does not occur. When a return is made to automatic mode, the switchover is both bumpless and drift-free. The setpoint ramp is not effective with x-tracking. However, the setpoint limiting is effective.

■ Filter and response threshold of negative deviation

All analog inputs have a selectable 1st order filter. The filter time constants TF1 to TF11 can be adjusted between 0.1 and 1000 s. In addition, the negative deviations are also fed via adaptive filters TFI and TFII in order to filter out low-frequency interferences:

Repeated oscillations which occur within a band are detected by the filter as noise and suppressed by the parameterized time constant. Should a change occur that is outside the band it is applied to the control algorithm without delay in order that control of the process is maintained. If the level of noise changes as time progresses, these filters automatically adapt to the new level.

Dead band elements can be incorporated into the negative deviation if the output of the controller (or of both controllers) is to be smoothed further more. Thus a symmetrical range is removed as response threshold AHI and AHII.

■ Matching the direction of action

The standard configuration of the controller is valid for normal-action systems. Should the controller be used with a reversely acting controlled system, the sign of the proportional gains K_{PI} and K_{PII} must be inverted. This applies to both the P- and I-components. The D-component however, can operate independently either in the same or reverse direction of the controlled variable.

■ Special features of the control algorithm

The P(D) or PI(D) control algorithm is implemented in both controllers as an interaction-free parallel structure and is of the same type irrespective of the output configuration S or K.

Two different sets of parameters can be stored in the device. These are assigned to controllers I and II in the dual-loop controller. When configuring as a single-loop controller, the binary signal PAU can be used to switch between parameter set I and parameter set II.

The switchover from PI to P control is made using the digital inputs PI and PII.

Switchover from automatic mode to manual mode and vice versa, as well as switching from all other modes to automatic mode, is bumpless.

If the controller is in P mode the working point y_0 is set automatically. If this is not required the working point can also be set manually as a parameter between 0.1 and 100 % using y_{0I} and y_{0II} . However, the switchover between manual and

automatic modes is not bumpless. In the case of three-position step controllers, P mode is only permissible with remote feedback of the final control elements position.

■ Limitation of manipulated variable

The manipulated variable of the K controller or an S controller with remote feedback can be limited by the parameters y_A and y_E . This limiting of the manipulated variable can be effective only in automatic mode or in all modes. If the manipulated variable reaches one of the limits y_A or y_E - depending on the setting - further integration is suppressed in addition to the limiting, and integral saturation cannot occur. Thus the manipulated variable is changed immediately if the polarity of the negative deviation changes.

If control is carried out outside the range y_A to y_E in manual, tracking, safety or DDC mode, the last manipulated variable is used bumplessly when returning to automatic mode. Modifications are only carried out in the direction of the limited range.

In addition to this fixed limitation of the manipulated variable, the SIPART DR22 controller contains a further direction-dependent manipulated variable limitation. The limitation is activated in this case via the digital inputs $\pm y_{BL}$ by remote signals. This limitation is effective in every mode.

■ Additional analog outputs, split-range mode

The total of 9 analog output can be assigned to all relevant, controller-internal variables, e.g. $x(x_v)$, $w(w_v)$, y , $(50\% + x_d)$, $(50\% - x_d)$, the inputs AE1A to AE11A or the function inputs FE1 to FE12.

It is possible to configure split-range mode if the SIPART DR22 controller is used as a K controller. As shown in Fig. 6/13, the output y_1 then always operates with a rising characteristic, a rising or falling characteristic can be selected for y_2 . The ranges of y_1 and y_2 can be parameterized. The three-digit display indicates y_1 or y_2 depending on which output is currently effective.

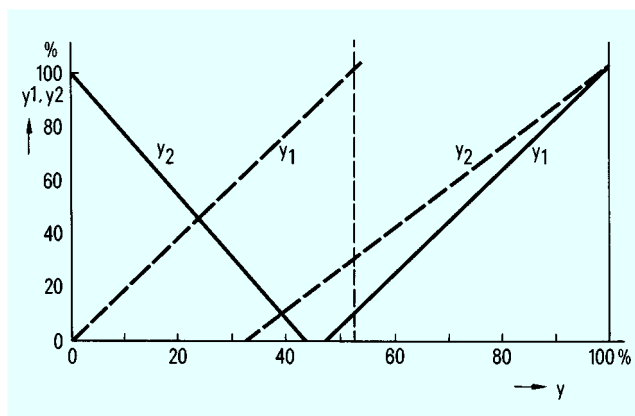

Fig. 6/13 Possibilities of split-range mode

■ Limit monitor

The alarm functions A1/A2 and A3/A4 can be assigned to the controller-internal process variables x_d , $x(x_v)$, $w(w_v)$, y , $(y_{1/2})$, the inputs AE1A to AE11A or the function inputs FE1 to FE12 for monitoring purposes. They can be configured to maximum or minimum monitoring.

Description

Upward or downward violations are indicated by the LEDs A1/A2 and A3/A4 (5 and 7, Fig. 6/14) and can be used for remote signalling by the digital outputs.

The alarms are normally set in the parameter mode. It is also possible to display and set the alarms in the process operation mode. The hysteresis of limit monitors can be parameterized between 0.1 and 10 %.

■ Parameter control

The parameter control function in the SIPART DR22 controller can be used to specifically control the parameters of the device determined at different working points. Thus the same control quality can be achieved throughout the complete load range when used with non-linear controlled systems or final control elements.

The proportional gain K_P , reset time T_n , derivative action time T_v , response threshold AH and – with the P controller – also the working point y_o are calculated using a straight line function with 5 vertices depending on the magnitude of a controlling variable. The vertices are at 10, 30, 50, 70 and 90 % of the controlling variable. This variable can be one of the internal process variables $x(x_v)$, $w(w_v)$, y or $10 \cdot |x_d|$ or one of the input signals AE1A to AE11A or one of the function inputs FE1 to FE12. The parameters effective at the vertices must first be determined and entered.

This procedure can be used with the dual-loop controllers in controller I or in controller II since both parameter set I and parameter set II can be selected for the parameter control. With the single-loop controllers it is therefore possible to select either a fixed or a controlled parameter set by means of the digital signal PAU.

■ Adaptation procedure

The SIPART DR22 controller contains an adaptation procedure for determining the optimal controller parameters which is based on the proven SIEPID procedure. The complete controlled systems step response is recorded. Process parameters, system gain, time constant and order are calculated using a procedure for optimum adaptation of models. Previous knowledge of the system is not required.

The controller parameters determined are for either a PI or PID controller. They can then be accepted directly or influenced by the user.

■ Blocking of the operator input level as well as the parameterization and configuring level

The controller offers 3 binary signals with which the following input levels can be blocked:

- The binary function BLB blocks operator inputs on the controller
- The digital input BLS blocks the switchover to the configuring mode. The on-line control parameters as well as adaptation can nevertheless still be set in addition to normal process operation.
- On the other hand, the digital input BLPS blocks the complete switching of the device from the process operation mode. Only normal operations such as manual changeover, are possible.

■ Restart conditions

Short dips in the input power supply voltage are overcome by the storage function of the power pack depending on the respective loading of the controller. In the event of a longer power failure, the set parameters and configurations are retained in a non-volatile, plug-in user program memory.

The current operating mode, the current setpoint and the current manipulated variable are also loaded into a non-volatile memory.

If the SIPART DR22 controller is equipped with the y-hold module and this module is supplied from a separate power supply unit, the current manipulated variable (I_y) is held at the output in the event of a power failure of the K controller.

When the power returns after an interruption or when it is switched on again, processing starts automatically with the modes configured. If the y-hold module held the manipulated variable current during the power failure, the controller starts bumplessly when the power returns. It is possible to configure visual indication via the display following a power failure.

■ Self-diagnostics

The internal exchange of data between the microcontrollers, the memories and the analog output module (y-hold) are checked cyclically and also following POWER ON or a watchdog reset by comprehensive monitoring circuits.

If a fault is detected, an error message is automatically output on the front displays, from which the cause and possible means of elimination can be understood.

When using the analog output module (y-hold), its digital output \overline{SI} interrupts the HIGH signal present during fault-free operation.

■ Communication with higher-level systems

The SIPART DR22 controller can transmit and receive status flags, process variables, parameters and configuring switch settings via an interface module (option).

The following interface modules are available:

PROFIBUS-DP module

- Transmission rate up to 1.5 Mbits/s
- Address range up to 125 (number of possible stations on the PROFIBUS is determined by the master interface module, the data range of the interface module, and the number of parameterized process data)

SES module RS 232

- Transmission rate 9.6 kbits/s
- RS 232 as point-to-point connection or SIPART bus up to 32 stations
- RS 485 bus up to 32 stations

The advantages of the autonomous SIPART DR22 single-loop controller can also be fully utilized together with higher-level systems:

- Problem-free adaptation of every controller to the problem
- Operational reliability; if the higher-level system or a part thereof is switched off or fails, the SIPART DR22 controller continues to operate as an autonomous controller with the conditions previously defined
- Flexibility; modifications or extensions to individual control loops are possible during operation of the complete system
- Both SPC and DDC modes are possible
- The higher-level system is relieved of certain tasks in SPC mode if the control functions are handled by the individual controller
- Distributed design of system results in clarity.

The configuring switches "S0" and "S251" as shown in Fig. 6/15 are the switches used to activate or configure the relevant functions (see pages 6/16 to 6/21).

Description

Control and display functions

The SIPART DR22 controller can be operated in three main modes:

- Process operation
- Selection level
- Configuring level (parameterization and configuring mode)

The pushbuttons and displays on the front of the controller sometimes have different functions in these three modes.

Process operation (Fig. 6/14)

Operation of the SIPART DR22 controller in process mode is clear and simple as a result of the arrangement and colors of the front, the controls and the inscriptions:

- **Red** is the color of the process variable:
The red display (16) and the red vertical LED bargraph (17) indicate the process variable.
- **Green** is the color of the setpoint:
The green display (19) and the green LED bargraph (18) indicate the setpoint. The green pushbutton (2) is used to switch between the local and remote setpoints. The local setpoint can be adjusted using the green pushbuttons (6). The green LED (1) signals operation with the local setpoint, the LED (3) also lights up green if the digital input DC is not present.
- **Yellow** is the color of the manipulated variable:
The yellow M/A pushbutton (9) is used to switch between manual and automatic modes, the yellow LED (8) signals by a steady or flashing light that a switch has been made to manual mode. Lighting up of the yellow LED (10) signals remote access to the manipulated variable, i. e. tracking, safety or blocking mode. The yellow pushbuttons (13) can be used in manual mode to adjust the manipulated variable which is displayed by the yellow digital display (14). The yellow LEDs (15) indicate the output of the positioning increment in all operating modes.

Upward or downward violations of limits are signalled when LEDs (5) and (7) light up. The LED (4) signals the process of parameter optimization during the adaptation procedure by means of a steady or flashing light.

The displays and setpoint pushbuttons are switched over in dual-loop controllers using the pushbutton (12). This pushbutton can also switch the display to indicate other setpoints and alarm values, when the SIPART DR22 controller is configured as a single-loop controller. The associated LED (11) indicates the status.

The label (20) is replaceable. The cover can be opened in the middle using a pointed tool and the label removed. A screw is then visible which can be used to remove the front module from the controller. The electrical connections between the front module and the basic unit are made via a ribbon cable.

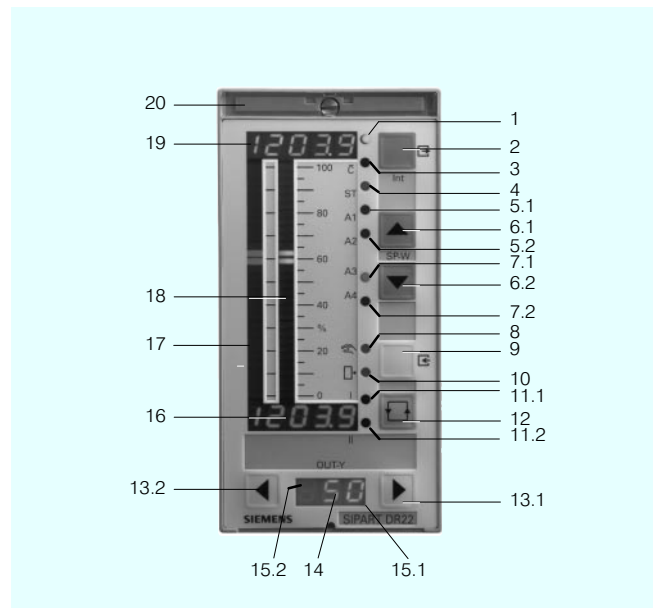

- | | |
|------|---|
| 1 | LED \square (green), signals "local setpoint" |
| 2 | Local/remote pushbutton/Exit pushbutton |
| 3 | LED \square (green), signals "No computer mode" |
| 4 | LED ADAPT (yellow)
Flashing light: adaptation in process
Steady light: adaptation terminated |
| 5.1 | LED A1 (red), signals "Limit A1 reached" |
| 5.2 | LED A2 (red), signals "Limit A2 reached" |
| 6.1 | Pushbutton $+\Delta w$ } Pushbuttons for adjustment |
| 6.2 | Pushbutton $-\Delta w$ } of local setpoint |
| 7.1 | LED A3 (red), signals "Limit A3 reached" |
| 7.2 | LED A4 (red), signals "Limit A4 reached" |
| 8 | LED (yellow)
Flashing light: manual mode, remote
Steady light: manual mode, local |
| 9 | M/A pushbutton for selection of manual/automatic mode/
Enter pushbutton |
| 10 | LED (yellow), lights up with remote y-intervention |
| 11.1 | LED I (green), control/display functions for controller I
Flashing light: display and effective functions are not identical
Steady light: display and effective functions are identical |
| 11.2 | LED II (green), control/display functions for controller II
Flashing light: display and effective functions are not identical
Steady light: display and effective functions are identical |
| 12 | Switchover pushbutton, for controller I/controller II |
| 13.1 | Pushbutton $+\Delta y$ } Pushbuttons to adjust the |
| 13.2 | Pushbutton $-\Delta y$ } manual manipulated variable |
| 14 | Digital display (yellow) for manipulated variable y |
| 15.1 | LED $+\Delta y$ (yellow) for display of manipulated variable increment
output with S controller |
| 15.2 | LED $-\Delta y$ (yellow) for display of manipulated variable increment
output with S controller |
| 16 | Digital display (red) for process variable x |
| 17 | Analog display (red) for process variable x |
| 18 | Analog display (green) for setpoint w |
| 19 | Digital display (green) for setpoint w |
| 20 | Replaceable tagging label; screw for loosening the front module
is behind this label |

Fig. 6/14 SIPART DR22 controller, control and display elements

Description

Selection level

The desired configuration menu is selected in the selection level. The controller switches back from the selection level to the process operation level after approx. 20 s.

The following configuration menus can be called:

onPA	Online parameters	
oFPA	Offline parameters	
PAST	Control parameters	
Strs	Configuring switch	
APst	All preset	
FdEF FCon FPoS FPST	Menus for the freely-selectable input range ¹⁾	
AdAP		Adaptation ¹⁾
CAE4		Calibration AE4 ¹⁾
CAE5		Calibration AE5 ¹⁾

¹⁾ Menu items are only displayed when enabled in StrS.

To call the selection level, the switchover pushbutton (12) must be held pressed until "PS" flashes in the digital display. After releasing the pushbutton, "onPA" appears in the digital display (19).

The controller is then in the selection level and operates in online mode.

Configuring level

The selected configuration menu can be called from the selection level, and settings can be carried out in this menu item.

Control mode is retained during configuring of the online parameters. The reaction of the controlled system to changes in the control parameters can thus be recognized immediately.

The controller output is blocked when adjusting the configuring switches of the offline parameters, the parameter control, the settings in the freely-selectable input area, or the setting of UNI mode:

- The K controller freezes the last manipulated variable current
- The S controller no longer outputs any positioning pulses.

The green analog display shows a striped pattern to indicate offline mode.

Lamp test

If the pushbutton (12) is pressed for longer than approx. 10 seconds, all LEDs on the front of the controller are triggered independent of the respective display, and remain on until the pushbutton is released. The original display is set again following the lamp function test.

Display of firmware release

The current firmware release of the SIPART DR22 controller can be displayed if required.

SIPART DR22 Controllers

6DR2210-

Description

Function diagram

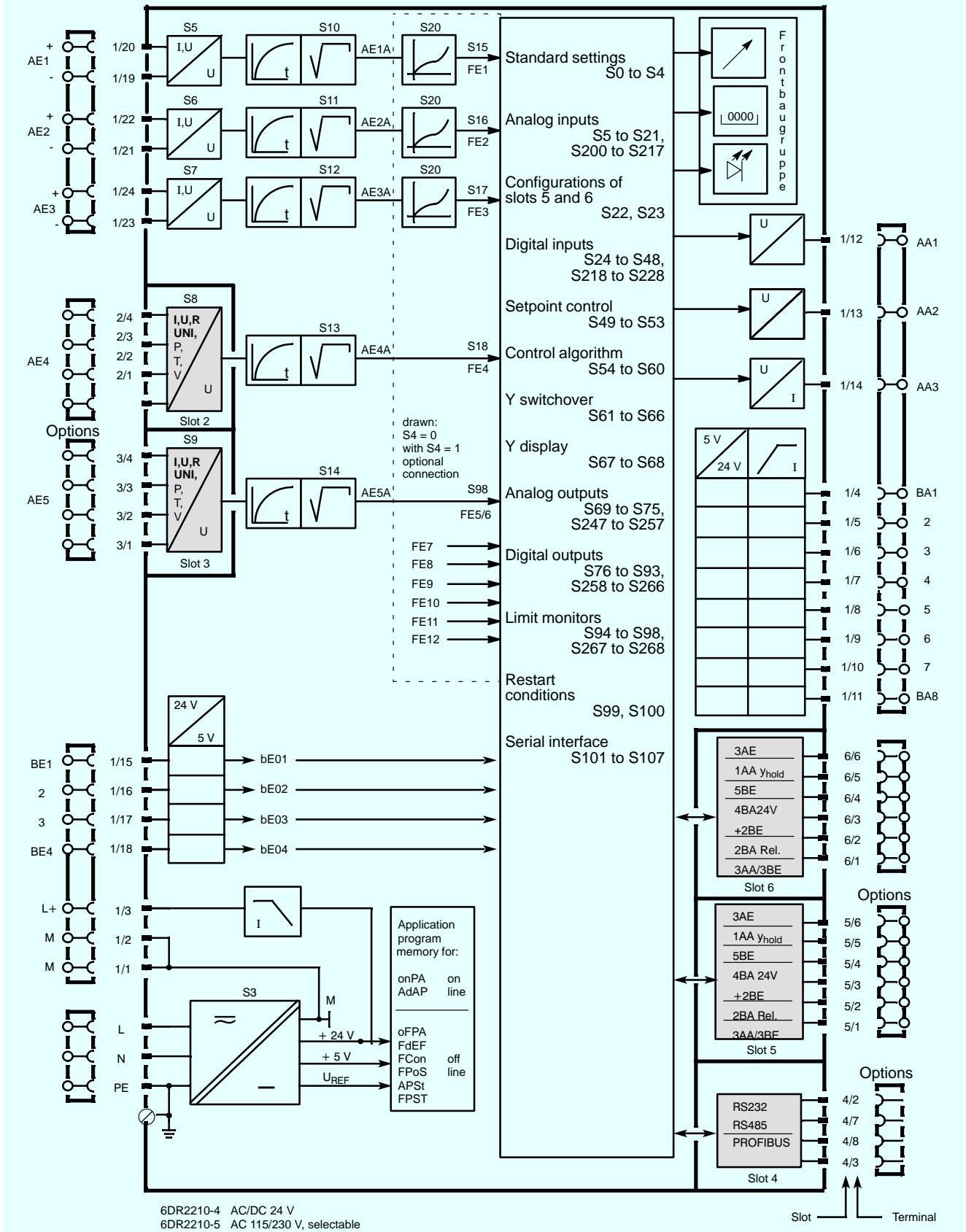

Optional

Fig. 6/15 SIPART DR22 controller, function diagram

Description

Adjustable on-line parameters

Parameter	Abbreviation	Display	Display (18), range of adjustment	Dimension	Remarks
Filter time constant for xdl	TF I	tFI	oFF, 1 to 1000	s	
Derivative action gain	Vv I	uul	0.1 to 10.0	1	
Proportional gain	Kp I	cPI	0.1 to 100.0	1	
Reset time	Tn I	tnI	1.000 to 9984	s	
Derivative action time	Tv I	tul	oFF, 1.000 to 2992	s	
Response threshold of xdl	AH I	AHI	0.0 to 10.0	%	
Working point	yo I	YoI	Auto, 0.0 to 100.0	%	P controller
Manipulated variable limiting, start-of-scale	yA I	YAI	- 10.0 to 110.0	%	yA < yE
Manipulated variable limiting, full-scale	yE I	YEI	- 10.0 to 110.0	%	yE > yA
Filter time constant for xdII	TF II	tFI	oFF, 1 to 1000	s	
Derivative action gain	Vv II	uull	0.1 to 10.0	1	
Proportional gain	Kp II	cPII	0.1 to 100.0	1	
Reset time	Tn II	tnII	1.000 to 9984	s	
Derivative action time	Tv II	tull	oFF, 1.000 to 2992	s	
Response threshold xdII	AH II	AHII	0.0 to 10.0	%	
Working point	yo II	YoII	Auto, 0.0 to 100.0	%	P controller
Manipulated variable limiting, start-of-scale	yA II	YAI	- 10.0 to 110.0	%	yA < yE
Manipulated variable limiting, full-scale	yE II	YEII	- 10.0 to 110.0	%	yE > yA
Repetition rate of display	dr	dr	0.08 to 8.00	s	
Positioning time Controller I/II	Ty 1/2	tY/tYII	10 to 1000	s	
Min. positioning pulse pause Controller I/II	TA 1/2	tA/tAII	20 to 600	ms	
Min. positioning pulse length Controller I/II	TE 1/2	tE/tEII	20 to 600	ms	
Filter time constant AE 1 to AE 11	TF 1 to TF 11	tF1 to tF11	oFF, 1 to 1000	s	
Constant c1 to c9	c 1 to c 9	c1 to c9	} - 1.999 to 9.999 or - 9.99 to 9.999	} 1 or 100 %	
Connectable parameter 1 to Connectable parameter 15	P 1 to P 15	P01 to P15	} - 1.999 to 9.999	} 1	} Only with S4 = 1

The decimal point, start-of-scale and full-scale values of the digital displays (16) and (19), response values and hysteresis of the pairs of alarms 1/2 and 3/4, setpoint limiting, safety setpoint and manipulated variable, setpoint ramp, ratio range, split ranges and the function generators (linearizers) are all set by **off-line parameters**.

SIPART DR22 Controllers

6DR2210-

Description

Configuring switches

Configuring switch	Function	Configuring switch	Function
S0	Identification of plug-in user program memory	S22 and S23	Fitting of slots 5 and 6
0	Code for factory setting (APSt)	S24 to S38	Assignment of control signals CB, He, N, Si, BLS, BLPS, PI, PII, PAU, $\pm \Delta w$, $\pm \Delta y$, $\pm y_{BL}$ to the digital inputs BE1 to BE14 or FE9 to FE12
1	} Selectable codes for user program	S39 to S46	Direction of action of control signals
.		S47 and S48	Direction of action of control signals CB and N, static or dynamic
.		S49 to S53	Setpoint control (tracking, source for remote setpoint, x-tracking)
.		S54 to S56	Direction of action of controller I/controller II
255		S55 to S57	D-element input of controller I/controller II, z feedforward
S1	Type of controller	S58	Adaptation: selection of time response
0	Fixed setpoint controller with 1 or 2 independent setpoints	S59 and S60	Parameter control: selection of controlled parameter and controlling variable
1	Fixed setpoint controller with 1 or 2 dependent setpoints	S61 to S66	Output switchover: priority N or H, source of external manipulated variable, function with split-range mode
2	DDC fixed setpoint controller	S67 and S68	Manipulated variable display: selection of displayed variable and direction of action of display
3	Slave/synchronization/SPC controller	S69 to S72	Signal range 0 or 4 to 20 mA of analog outputs AA1 to AA4
4	Ratio controller	S73 to S75	Assignment of analog outputs AA1 to AA3 to controller signals
5	Cascade controller	S76 to S85	Assignment of signals \overline{RB} , \overline{RC} , H, N, A1, A2, A3, A4, MUF and Int I to digital outputs BA1 to BA16
6	Ratio cascade controller	S86 to S93	Direction or action of signals \overline{RB} , \overline{RC} , H, N, A1/A2, A3/A4, MUF and Int I
7	Override controller, max. limiting of y	S94 and S95	Assignment of limit monitors A1/A2 and A3/A4 to internal controller signals
8	Override controller, min. limiting of y	S96 to S98	Function and setting of limit monitors
9	Process variable display	S99 and S100	Restart conditions following power failure
10	Fixed setpoint controller for coupling to a process control system	S101 to S107	Settings of serial interface: transmission rate, parity, station no.
11	Slave controller for coupling to a process control system		
12	Dual loop controller		
S2	Output configuration		
0	K output		
1	S output with internal feedback		
2	S output with external feedback		
S3	Mains frequency suppression		
0	For 50 Hz		
1	For 60 Hz		
S4	Input connections		
0	Standard connections		
1	Optional connections (Fig. 6/3)		
S5 to S9	Signal range 0 or 4 to 20 mA of analog inputs AE1 to AE5 or UNI Module AE4 and AE5		
S10 to S14	Square-rooting of analog inputs AE1 to AE5		
S15 to S19	Assignment of function inputs FE1 to FE6 to the analog inputs (with S4 = 0)		
S20 and S21	Switching on/off linearizers FE1 and FE3 (only with S4 = 0)		

The table above lists the configuring switches S0 to S4 of the SIPART DR22 controller with their possible settings in detail. Only the selectable functions are defined for the other configuring switches. A detailed list is provided in the operating instructions of the controller.

Description

Configuring switches (continued)

Configuring switch	Function
S200 to S205	Signal range 0 or 4 to 20 mA of analog inputs AE6 to AE11
S206 to S211	Square-rooting of analog inputs AE6 to AE11
S212 to S217	Assignment of function inputs FE7 to FE12 to the analog inputs (with S4 = 0)
S218 to S228	Assignment of control signals BLB, CBII, HeII, NII, SII, /tSII, /tSII, WSLI, WSLII, +yBLII, -yBLII to the digital inputs BE1 to BE14 or FE9 to FE12
S229 to S230	Direction of action of control signals tS und WSL
S231	Output structure of controller 2 (with dual-loop controller)
S232 to S235	Setpoint control of controller 2 (with dual-loop controller)
S237 to S238	Source of manipulated variable w1/w2
S239 to S244	Output circuit of controller 2 (with dual-loop controller)
S245 to S246	Effect of manipulated variable limiting
S247 to S251	Signal range 0 or 4 to 20 mA of analog outputs AA5 to AA9
S252 to S257	Assignment of analog outputs AA4 to AA9 to internal controller signals
S258 to S266	Assignment of signals and function inputs FE9 to FE12 to digital outputs BA1 to BA16
S267 to S268	Assignment of alarms A2 to A4 to internal controller signals

SIPART DR22 Controllers

6DR2210-

Technical data

Technical data	
General	
Mounting position	Any
Climatic classes	
- Storage: 1K2 according to DIN IEC 721 Part 3-1	-25 to +75 °C
- Transport: 2K2 according to DIN IEC 721 Part 3-2	-25 to +75 °C
- Operation: 3K3 according to DIN IEC 721 Part 3-3	0 to +50 °C
Degree of protection to EN 60 529	
Front	IP 64
Housing	IP 30
Connections	IP 20
Controller design	
to DIN EN 61 010 Part 1 (March 1994)	
- Protection class I to IEC 536	
- Isolation between mains connection and field signals by double insulation or protective shield to DIN/VDE 0106, Part 101 (Nov. 1986) (IEC 536).	
- The output voltages are extra-low voltages and isolated from the mains connection to DIN/VDE 0100, Part 410 (Nov. 1983).	
- Clearance and creepage paths, if not specifically stated otherwise, for overvoltage class III and contamination class II to DIN/VDE 0110, Part 1 (Jan. 1989).	
The SIPART DR22 controller has already acquired the following approval and identification:	
<ul style="list-style-type: none"> • CE marking The controller conforms with following harmonized standards: EG conformity decl. No. DR22/24-2/98, EMC Guidelines 89/336 EWG	
- Emitted interference DIN EN 50 081-Part 2, Issued: 3/1994	
- Immunity of interference DIN EN 50 082-Part 2, Issued: 3/1995	
NS Guidelines 73/23 EWG	
- EN 61 010 Part 1, Issued: 3/1993 EN 60 529, Issued 6/1991	
<ul style="list-style-type: none"> • DIN approval for test and inspection mark for temperature controller requested • TÜV certificate on approval of a component symbol for water level controller requested 	
Weight (standard controller without options)	Approx. 1.2 kg
Color	
Front module frame	RAL 7037
Front module facia	RAL 7035
Material	
Housing and front frame	Polycarbonate, glass-fiber reinforced
Front facia foil	Polyester
Power supply connection	
AC 115/230 V	3-pin earthed plug IEC 320/V
AC/DC 24 V	Special 2-pin plug
Connections for process signals	Multiple screw terminal blocks, cannot be confused when connecting, for conductor cross-section 1.5 mm ² (AWG 14)
Protective earth connection	Earthing screw
A rail can be mounted on the rear panel of the power supply. The rail is included in the delivery of the coupling relay mode.	

Power supply			
Rated voltage	Selectable		AC/DC 24 V
	AC 230 V	AC 115 V	
Operating voltage range	AC 187 to 276 V	AC 93 to 138 V	DC 20 to 35 V ⁴⁾
Frequency range	48 to 63 Hz		-
Peak voltages, non periodic, to VDE 160			
1.3 ms	≤ 780 V	≤ 390 V	≤ 70 V
10 μs	≤ 1500 V	≤ 1500 V	≤ 500 V
External current <i>I</i> _{Ext} ⁵⁾	450 mA		
Power consumption			
Active power/ apparent power ⁶⁾			
Standard controller			
- Without options, without <i>I</i> _{Ext}	8 W/17 VA	8 W/13 VA	8 W/11 VA
- With options, without <i>I</i> _{Ext}	13 W/25 VA	13 W/20 VA	13 W/18 VA
- With options, with <i>I</i> _{Ext}	26 W/45 VA	26 W/36 VA	28 W/35 VA

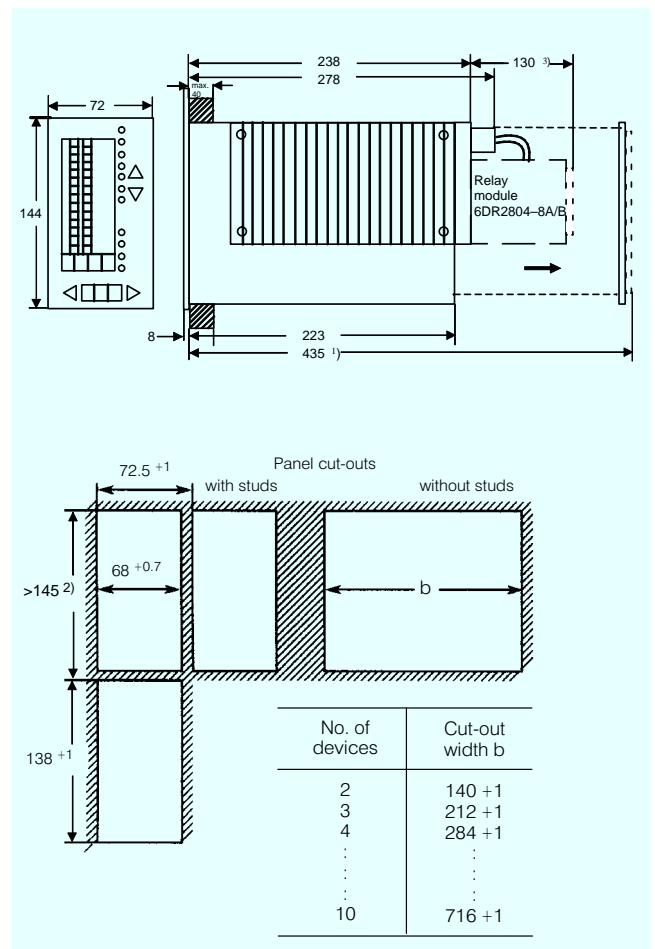

Fig. 16/16 SIPART DR22 controller and panel cut-outs, dimensions

¹⁾ Mounting depth required to enable replacement on the main circuit board.

²⁾ Mounting one above the other without interspacing is permissible if the permissible ambient temperature is observed.

³⁾ A relay module with 2 or 4 contacts (6DR2804-8A/-8B) can be snapped onto the rear of the controller; the mounting depth is then increased by 130 mm.

⁴⁾ Including harmonics.

⁵⁾ Consisting of L+, BA and AA.

⁶⁾ Capacitive.

Technical data

Technical data (continued)

Power supply (continued)				
Permissible voltage dips ¹⁾ Standard controller - Without options, without I_{Ext} - With options, without I_{Ext} - With options, with I_{Ext}	≤ 90 ms	≤ 70 ms	≤ 55 ms	≤ 30 ms
	≤ 80 ms	≤ 60 ms	≤ 50 ms	≤ 25 ms
	≤ 50 ms	≤ 35 ms	≤ 35 ms	≤ 20 ms
Test voltages (1 min) - Primary - secondary - Primary - protective earth conductor - Secondary - protective earth conductor	AC 1.5 kV		AC 500 V	
	AC 1.5 kV		AC 500 V	
	DC 700 V		DC 700 V	
Inputs and outputs, display technology				
Analog inputs AE1, AE2, AE3 and AE6 to AE11 (input module 6DR2800-8A)				
Input signal range	0/199.6 to 998 mV or 0/2 to 10 V			
Voltage	0/4 to 20 mA			
Current				
Input impedance				
Differential (voltage)	200 k Ω			
Differential (current)	49.9 Ω \pm 0.1 %			
Common-mode	> 500 k Ω			
Common-mode voltage	0 to 10 V			
Filter time constant	50 ms			
Effect of temperature				
Zero	0.05 %/10 K			
Gain	0.1 %/10 K			
Analog outputs AA1 to AA3				
Rated signal range	0 to 20 mA or 4 to 20 mA			
Operating range	0 to 20.5 mA or 3.6 to 20.5 mA			
Load voltage	-1 to +18 V			
Max. inductive load	≤ 0.1 H			
No-load voltage	≤ 26 V			
Time constant	300 ms			
Residual ripple 900 Hz	≤ 0.2 %			
Resolution	≤ 0.1 %			
Zero error	≤ 0.3 % of measuring span			
Gain error	≤ 0.3 % of measuring span			
Linearity error	≤ 0.05 % of measuring span			
Load dependence	≤ 0.1 %			
Effect of temperature				
Zero	≤ 0.1 %/10 K			
Gain	≤ 0.1 %/10 K			

Transmitter supply $L+$	
Rated voltage	20 to 26 V
On-load current	≤ 100 mA, short-circuit proof
Short-circuit current	≤ 200 mA pulsed
Digital inputs BE1 to BE4	
Signal status "0"	≤ 4.5 V or open
Signal status "1"	≥ 13 V
Static destruction limit	± 35 V
Input impedance	≥ 27 k Ω
Digital outputs BA1 to BA8 (connected via wired-OR diodes)	
Signal status "0"	≤ 1.5 V
Signal status "1"	+19 to 26 V
On-load current	< 50 mA
Short-circuit current	< 80 mA pulsed
Cycle time	
> 60 ms, user program dependent	
A/D conversion	
Method	Successive approximation with > 120 measurements per input and averaging over 20 or 16.67 ms
Resolution	11 bit ± 0.06 %
Zero error	≤ 0.2 % of the measuring span
Gain error	≤ 0.2 % of the measuring span
Linearity error	≤ 0.2 % of the measuring span
Effect of temperature	
Zero	≤ 0.05 %/10 K
Gain	≤ 0.1 %/10 K
Display technology	
Digital x, w displays	
Color	w display x display
Digit height	4 $\frac{1}{2}$ digit, 7-segment LEDs
Display range	Green
Numeric range	Red
Decimal point	7 mm
Refresh rate	Adjustable start/full scale
Resolution	-1999 to 19999
Display error	Variable
	0.08 to 8.0 s, adjustable
	1 digit, but not better than A/D converter
	Corresponding to A/D converter and analog inputs
Digital y display	3-digit, 7-segment LEDs
Color	Yellow
Digit height	7 mm
Display range	0 to 100 %
Refresh rate	0.08 to 8.0 s, adjustable
Resolution	1 %
Analog displays	
Color	w display x display
Display range	Green
Resolution	Red
Refresh rate	LED array with 30 LEDs / 0 to 100 %
	1.7 % by alternate lighting of 1 or 2 LEDs, the center point of the illuminated LEDs acting as a pointer
	0.08 to 8.0 s, adjustable

¹⁾ The load voltage of the analog outputs is reduced to 13 V, $L+$ to +15 V and the voltage at the digital outputs drops to +14 V.

SIPART DR22 Controllers

6DR2210-

Ordering data

Ordering data	
	Order No.
SIPART DR22 controller 72 x 144 Basic unit with <ul style="list-style-type: none"> - 3 analog inputs, - 3 analog outputs, - 4 digital inputs, - 8 digital outputs and - user program memory <ul style="list-style-type: none"> • power supply AC/DC 24 V • power supply AC 230 V, switchable to AC 115 V 	<p>6DR2210-4</p> <p>6DR2210-5</p>
Input/output modules Analog signal module <ul style="list-style-type: none"> - for current input 0/4 to 20 mA or voltage inputs 0/0.2 to 1 V or 0/2 to 10 V (6DR2800-8J) - for resistance based sensor (6DR2800-8R) - UNI module for TC/RTD/R/mV signals, programmable (6DR2800-8V) - Reference junction terminal for TC, internal (to be used in conjunction with UNI module (6DR2805-8A) - Measuring range connector for $I = 20 \text{ mA}$ and $U = 10 \text{ V}$ (to be used in conjunction with UNI module) (6DR2805-8J) - with 3 analog outputs 0/4 to 20 mA and 3 digital inputs (6DR2802-8B) - with 3 analog inputs 0/4 to 20 mA or 0/0.2 to 1 V or 0/2 to 10 V (6DR2800-8A) - y-hold module (6DR2802-8A) Switching signal module <ul style="list-style-type: none"> - with 5 digital inputs (6DR2801-8C) - with 4 digital outputs and two digital inputs (6DR2801-8E) - with 2 relay outputs (6DR2801-8D) Coupling relay module <ul style="list-style-type: none"> - With 2 relays (AC 250 V) (6DR2804-8A) - With 4 relays (AC 250 V) (6DR2804-8B) Interface modules <ul style="list-style-type: none"> - For serial communications (SES) via RS 232 or RS 485 (6DR2803-8C) - PROFIBUS-DP module (6DR2803-8P) 	<p>See Catalog MP 31, Section 8</p> <p>See Page 6/26</p>
Documentation SIPART DR22 controller <ul style="list-style-type: none"> - German - English Mounting and installation instructions, German/English Operating Instructions "SIPART DR22 Serial Interface" <ul style="list-style-type: none"> - German - English 	<p>C79000-G7400-C154 C79000-G7476-C154</p> <p>C79000-M7474-C38</p> <p>on request on request</p>

Scope of supply

The scope of supply of a SIPART DR22 controller includes:

- 1 Controller as ordered
- 1 Power supply connector 115/230 V or a special connector for AC/DC 24 V supply
- 2 Clamping elements, pluggable
- 1 Mounting and installation instructions (German/English)

Available ex-stores

Items marked are available ex-stores.

Input/output modules and accessories

The input/output modules are described in Catalog MP 31, Section 8. Exception: 6DR2802-8B, see page 6/26.

Section 9 of the catalog contains details about software for parameterizing the controller from a PC, interfacing to systems and the necessary accessories (connectors, line drivers, etc.).

Training

Refer to ITC catalog (German) for details of training courses for the controllers listed in this catalog.

Note:

When using the SIPROM DR program, only the scope of functions of the previous SIPART DR22 controller can be utilized with the innovated SIPART DR22 controller "new" (6DR2210-...).

The additional functions can only be utilized with direct programming on the front panel of the controller until admission in SIMATIC PDM "new".

It is currently envisaged that the incorporation in PDM will be available in August 1999.

Overview: applications

Analog signal modules	SIPART DR22					Description see Catalog MP31, Page
	Slot 2	Slot 3	Slot 4	Slot 5	Slot 6	
U/I module 6DR2800-8J	AI4	AI5	-	-	-	8/3
3 x U/I module 6DR2800-8A	-	-	-	AI9/10/11	AI6/7/8	8/4
R module 6DR2800-8R	AI4	AI5	-	-	-	8/5
Pt 100 module 6DR2800-8P	(AI4)*	(AI5)*	-	-	-	8/6
TC module 6DR2800-8T	(AI4)*	(AI5)*	-	-	-	8/7
UNI module 6DR2800-8V (TC/RTD/R/U/I)	AI4	AI5	-	-	-	8/8
y-hold module 6DR2802-8A	-	-	-	AO7	AO4	8/10
3AO/3DI module 6DR2802-8B	-	-	-	AO7/8/9 DI5/6/7	AO4/5/6 DI10/11/12	Supplement May 1999, 6/26

NEW

*) Use the UNI module 6DR2800-8V.

Switching signal modules	SIPART DR22					Description see Catalog MP31, Page
	Slot 2	Slot 3	Slot 4	Slot 5	Slot 6	
5 DI 6DR2801-8C	-	-	-	DI5/6/7/8/9	DI 10/11/12/13/14	8/11
2 relays 6DR2801-8D	-	-	-	DO9/10	DO13/14	8/12
4DO/2DI 6DR2801-8E	-	-	-	DO9/10/11/12 DI5/6	DO13/14/15/16 DI10/11	8/13

Interface module	SIPART DR22					Description see Catalog MP31, Page
	Slot 2	Slot 3	Slot 4	Slot 5	Slot 6	
SES module 6DR2803-8C						8/14
RS 232/SIPART bus	-	-	Yes	-	-	
RS 485	-	-	Yes	-	-	
PROFIBUS-DP module 6DR2803-8P	-	-	Yes	-	-	8/15

NEW

Coupling relay module can be installed on rear:	SIPART DR22	Description see Catalog MP 31, Page
with 4 relays 6DR2804-8A	Yes	8/16
with 2 relays 6DR2804-8B	Yes	8/16

Depending on the application, the following can be used in conjunction with the UNI mo- dule 6DR2800-8V:	Description see Catalog MP 31, Page
Reference junction terminal 6DR2805-8A	8/8
Measuring range connector 6DR2805-8J	8/8

SIPART DR22 Input/Output Modules

6DR2802-8B

Module 3AO/3DI

- 3AO/3DI module 6DR2802-8B for extension of analog outputs and digital inputs

The 3AO/3DI module is suitable for use in the SIPART DR22 and DR24 controllers.

Assignment of functions and the logic is performed using the configuring switches.

The screw-type terminal is supplied with the module.

Technical data 6DR2802-8B

3AO/3DI module	
Analog outputs	
Rated signal range (0 to 100 %)	0 to 20 mA or 4 to 20 mA
Output range	0 to 20.5 mA or 3.8 to 20.5 mA
Load voltage	-1 V to 18 V
No load voltage	≤ 26 V
Inductive load	≤ 0.1 H
Time constant	10 ms
Residual ripple 900 Hz	≤ 0.2 %
Resolution	10 Bit
Load dependence	≤ 0.1 %
Zero error	≤ 0.3 %
Gain error	≤ 0.3 %
Linearity error	≤ 0.05 %
Digital inputs	
Signal status "0"	≤ 4,5 V or open
Signal status "1"	≥ 13 V
Input resistance	≥ 27 kΩ
Static destruction limit across inputs	± 35 V

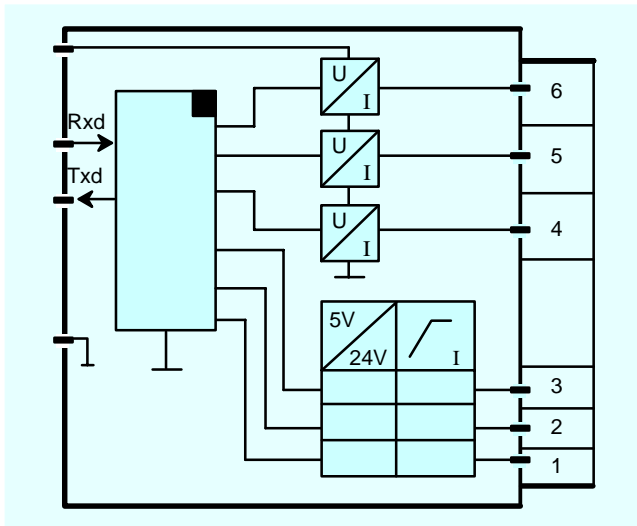

Fig. 6/17 Wiring of 3AO/3DI module

Assignment of the terminals to the analog output (AO) and the digital input (DI); depending on slot

Terminal	SIPART DR22/DR24	
	Analog outputs	
	Slot 5	Slot 6
6	AO9	AO6
5	AO8	AO5
4	AO7	AO4
Terminal	Digital inputs	
	Slot 5	Slot 6
	3	DI7
2	DI6	DI11
1	DI5	DI10



Ordering data

	Order No.
Analog signal module 3AO/3DI module to extend the analog outputs and digital inputs	6DR2802-8B

Available ex-stores

Conditions of Sale and Delivery

Subject to the General Conditions of Supply and Delivery for Products and Services of the Electrical and Electronics Industry and to any other conditions agreed upon with the recipients of catalogs.

The technical data, dimensions and weights are subject to change unless otherwise stated on the individual pages of this catalog.

The illustrations are for reference only.

The General Conditions for Software Products for Automation shall apply to software products.

Year 2000 compatibility

The change of the year 2000 affects not only data processing systems but also products, systems and plants using automation and drives technology.

Apart from hardware and software components, user programs which process calendar dates are especially affected by this change to the year 2000.

We at Siemens in the Automation and Drives Group have set this topic of year 2000 compatibility as a high priority in order to provide our customers with as smooth a transfer as possible into the next millenium.

The behavior of our products is being given a detailed examination employing the test profiles of the British Standards Institution (BSI), which have met with international acceptance. The results of this examination can be found in our "Year 2000" database in the Internet under:

<http://www.ad.siemens.de/jahr2000>

Combinations of products and systems in plants as well as individual adaptations and/or expansions of product and system constellations can result in errors or faults in of individual product or system functioning and/or of the entire plant with the change to the year 2000.

Should you have any questions contact your local Siemens representative.



Export

The products listed in this catalog may be subject to European, German or U.S. export regulations.

Any export under restriction requires approval by responsible authorities.

Information thereon can be obtained from our acknowledgements, delivery notes and invoices.

A&D/MP/e En 7.96

Process automation in the World Wide Web (WWW)

You can access information concerning the Automation and Drives Group in the World Wide Web under the address:

<http://www.ad.siemens.de>

Information concerning the *Products, Systems and Solutions for the Process Automation* can be found under the Internet address:

http://www.ad.siemens.de/product/html_00/adpa.htm

Appendix

Notes

Notes

