

Overview

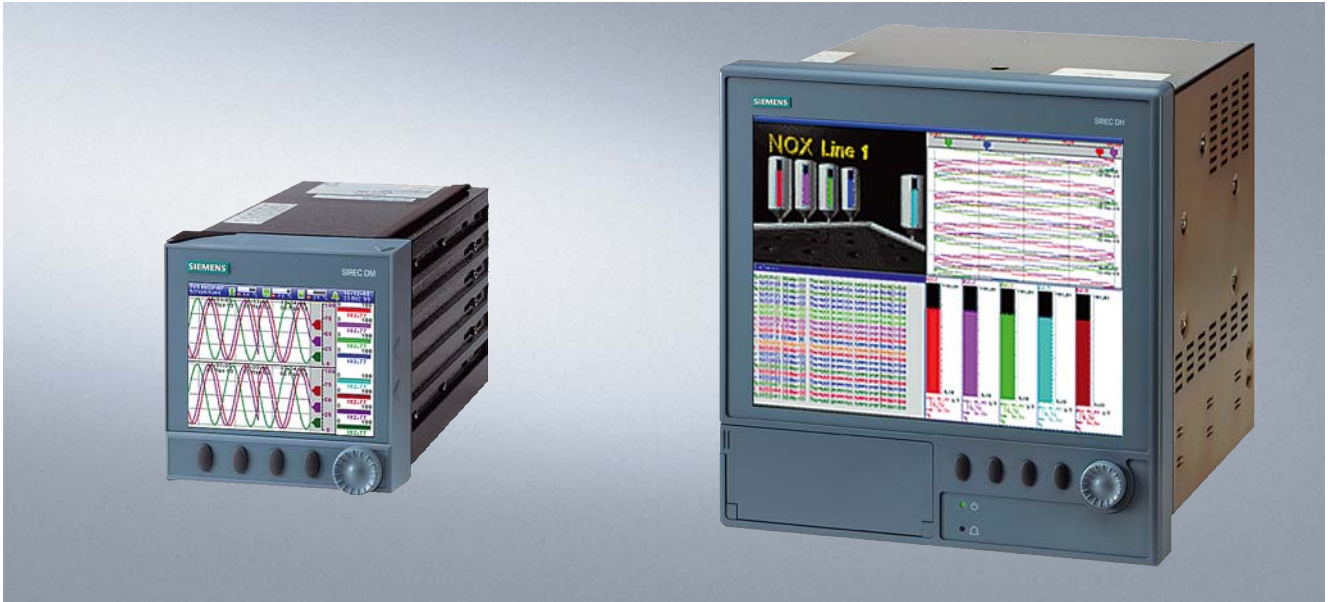

- Permits the recording of up to 16 analog inputs and 16 binary inputs (SIREC DM) or 32 analog inputs and 32 binary inputs (SIREC DH)
- Output on a color LC display (TFT)
 - 5.5" with SIREC DM
 - 12.1" with SIREC DH
- Storage of data on 1.44 Mbyte diskette or PCMCIA card (ATA flash type II)
- Ethernet interface as standard
- Data evaluation using the SIREC D-Viewer PC program (included in scope of delivery)
- Programming from the front panel or using the SIREC D-Manager PC program (option)
- Full network functionality (FTP, real-time Trendbus, Modbus) with the SIREC D Server PC program (option)
- Web server function

Application

The SIREC DM/DH recorders are used to record and display electrical variables.

The measured data in the main memory are available on the display for direct observation of the trend. The measured data on the replaceable data memory are evaluated on a PC.

- The input variables can be freely adjusted within wide ranges. The unit is therefore suitable for almost all process engineering sectors.
- The binary inputs and binary outputs permit control of the unit or also the output of signals.
- The recorder can be connected to a PC via Ethernet to permit central acquisition of the measured data.
- Comprehensive mathematical functions are optionally available.

Design

In housing for panel mounting; front dimensions 144 x 144 mm (SIREC DM) or 300 x 300 mm (SIREC DH).

The units are operated and set using an input panel (keys and spinwheel) on the front panel.

The drives for data storage (diskette drive and slot for PCMCIA card) are located behind the display (SIREC DM) or behind a cover (SIREC DH) and are readily accessible. The PCMCIA cards are not included in the scope of delivery.

The type and quantity of measuring inputs and switching outputs/inputs depends on the order. The number of terminals can therefore vary depending on the configuration.

The electric connections are made at the rear of the recorder:

- Power supply connection: appliance plug for 90 to 250 V AC version
- Power supply connection: screw terminals for 24 V DC version
- Process signal connections: plug-in screw terminals
- Ethernet TCP/IP interface connection: 8-pin RJ45 connector

The signal inputs "Fast sampling" for the current ranges have an internal shunt (switch).

External shunts are required for the option "Universal card with high EMC".

SIREC D display recorder

SIREC DM and SIREC DH

Function

The process variables are measured, and displayed as trend curves, bargraphs or digital displays in various combinations.

The internal memory (4 Mbyte with SIREC DM, 8 Mbyte with SIREC DH) is operated as a ring buffer. The oldest data in each case are overwritten by the newest data.

The following versions are possible for data recording on diskette or PCMCIA card:

- Selective data storage per channel. Individual selection of storage method and rate
- Optional data compression using fuzzy logging mode (selectable per channel)

Display of measured data

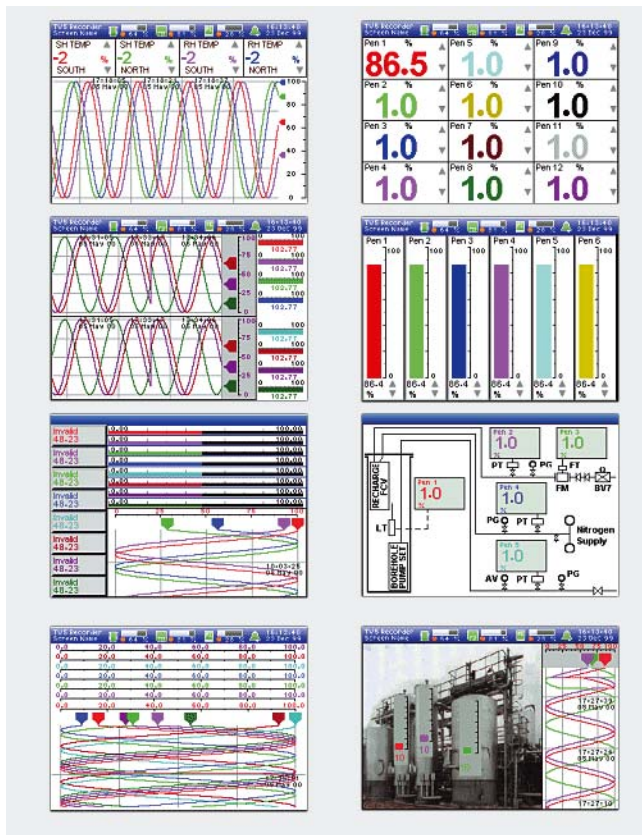

SIREC DM display modes

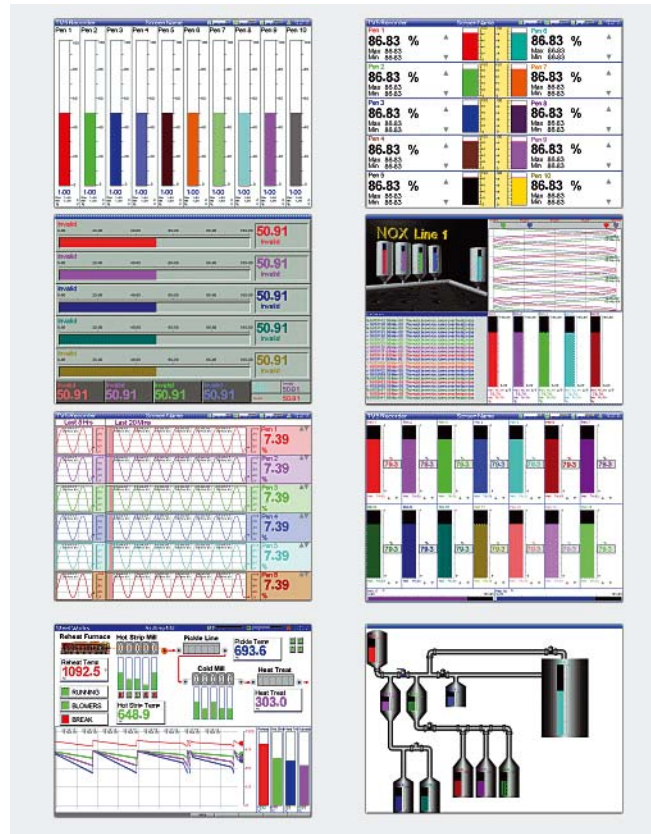

SIREC DH display modes

The display of the measured data can be freely adjusted within wide ranges, permitting:

- Analog trend display up to 12,000 mm/h
- Horizontal or vertical analog display
- Horizontal or vertical bargraph
- Detailed alarm and event reports
- Numerical display of values
- Event marking with I&C number, time and date
- Status line with date, time, occupation of RAM and diskette in percent
- Customized display and plant displays (SIREC DH)

Further important features

- Simple and fast configuration on the device or using software
- Operating menu in German, English, French, Italian, Spanish, Portuguese, Polish, Hungarian, Slovakian, Czech, Romanian, Turkish
- User-defined access coding with password protection. There are four access levels; up to 10 different passwords are possible.
- Enhanced security system ESS; with this option, the two SIREC DM/DH recorders comply with the requirements of FDA 21CFR Part 11
- Real-time clock with calendar function (with lithium backup battery, service life 10 years)

Technical specifications

Inputs

Quantity	
• SIREC DM	8, 12 or 16 input channels
• SIREC DH	24 or 32 input channels

Sampling rates

• Fast sampling card	
- mA, mV	200 ms (5 Hz)
- Thermocouples/PT100	500 ms (2 Hz)
• Universal card	
- mA, mV, thermocouples/PT100	500 ms (2 Hz)

Measured variables and measuring range limits

Transmitter power supply

• SIREC DM	18 ... 24 V; 1 A
• SIREC DH	18 ... 24 V; 0.2 A

Electrical isolation

100 V DC between the channels, 300 V DC between channels and ground

Input variables

• DC voltage	$\pm 1 \text{ V}, \pm 10 \text{ V}$ $\pm 100 \text{ mV}, \pm 200 \text{ mV}$
• Direct current	$\pm 10 \text{ mA}, \pm 20 \text{ mA}$
- Resolution	16 bits A/D converter (0.0015%)

Effects of ambient temperature

• Voltage input	0.005%/°C
• Current input	0.02%/°C

Input resistance, voltage inputs

> 1 M Ω

Current loop resistance

• Fast sampling card	Internal, approx. 10 Ω \pm 5%
• Universal card	With external 250 Ω shunt

Fast sampling card

Thermocouples

	Temperature range
• C (W5)	0 ... 2300 °C
• E	-200 ... 0 °C 0 ... 1000 °C
• J	-200 ... 0 °C 0 ... 1190 °C
• K	-200 ... 0 °C 0 ... 1000 °C 1000 ... 1350 °C
• L	-200 ... +900 °C
• N (Nicrosil Nisil)	-200 ... 0 °C 0 ... 1300 °C
• T	-200 ... 0 °C 0 ... 400 °C
• W	1000 ... 2300 °C
• Nickel/cobalt	-50 ... +1300 °C
• Chromel/Copel	-50 ... +600 °C

Resistance thermometers

	Temperature range
• Pt100, 100 Ω	-200 ... +650 °C
• Pt200, 200 Ω	-200 ... +180 °C
• Nickel 100 Ω	-60 ... +180 °C
• Nickel 120 Ω	-80 ... +240 °C

Universal card

Thermocouples

	Temperature range
• B	0 ... 260 °C 260 ... 538 °C 538 ... 1820 °C
• C (W5)	0 ... 316 °C 316 ... 1982 °C 1982 ... 2300 °C
• E	-200 ... -130 °C -130 ... +1000 °C
• J	-18 ... +871 °C
• K	-18 ... +1316 °C
• L	-200 ... +900 °C
• N (Nicrosil Nisil)	-18 ... 1300 °C
• R	-18 ... +260 °C 260 ... 1704 °C
• S	-18 ... +260 °C 260 ... 1704 °C
• T	-184 ... +371 °C
• W ₂₆	1000 ... 2300 °C
• Nickel/cobalt	-50 ... +1360 °C
• Chromel/Copel	-50 ... +600 °C

Resistance thermometers

	Temperature range
• Pt100, 100 Ω	-184 ... +649 °C
• Pt200, 200 Ω	-184 ... +649 °C
• Nickel 100 Ω	-60 ... +180 °C
• Nickel 120 Ω	-80 ... +240 °C
• Cu10	-20 ... +250 °C
• Cu53	0 ... 150 °C

Source resistance

• Thermocouple	Approx. 0.5 °C/100 k Ω (1 k Ω max.)
• Resistance thermometer	Approx. 0.1 °C/ Ω (40 Ω max.)

Cold junction compensation

• Accuracy	Internal auto, external 0 °C ± 1 °C
• Influence of cold junction compensation	0.03 °C/°C

Integration time

50/60 Hz for suppression of system hum

Attenuation

Adjustable to an interval of 1 s to 15 s to generate the mean value of an incoming signal

Electrical isolation

• Fast sampling card	100 V DC between channels and between channels and ground
• Universal card	400 V DC between channels and between channels and ground

Linear scaling

-999999 to +999999 with a scaling factor from 1 to 9999; automatic selection of decimal point; freely-definable technical dimensions (5 characters)

Logarithmic scaling

1 to 9 decades

Square-root extraction

For all input modes

• Scaling limits	$\pm 1.000.000$
• Decimal places	User-adjustable
• Technical dimensions	Freely-definable, up to 12 characters

Display

Industry-type LCD (TFT)	
Size	
• SIREC DM	5.5" (14 cm) diagonal, color
• SIREC DH	12.1" (30.7 cm) diagonal, color
Resolution	
• SIREC DM	QVGA (320 x 240 pixels)
• SIREC DH	SVGA (800 x 600 pixels)
Temperature dimensions	°C, °F or K (Kelvin)
Trend display	1 ... 12000 mm/hour

SIREC D display recorder

SIREC DM and SIREC DH

Conditions for use

Installation conditions

Mounting Vertical panel mounting, max. $\pm 15^\circ$ out of horizontal

Ambient conditions

Permissible ambient temperature

- Operation 0 ... 50 °C
- Storage -10 ... +60 °C

Warm-up time At least 30 min

Relative humidity 10 ... 90 % (no condensation)

Vibration 5 ... 100 Hz, 10 ms

Shock 1 g

Magnetic field 450 AT/m (0 ... 60 Hz)

Degree of protection

- Housing (front) IP40
- Terminals IP20

Design

Weight

- SIREC DM 3 kg
- SIREC DH 10 kg

Housing material

- SIREC DM Extruded aluminium
- SIREC DH Galvanized steel plate, passivated

Front frame material

- SIREC DM Injection-molded ABS
- SIREC DH Aluminium, with gray powder-coated polyester

Dimensions (W x H x D) in mm

- SIREC DM 144 x 144 x 285
- SIREC DH 300 x 300 x 285

Recommendation: provide additional 30 mm for mains cable and signal plug.

Mounting

Flush mounting in vertical panels; panel thickness: 2 ... 100 mm

Power supply

Supply voltage 90 ... 264 V AC
24 V DC (9 ... 36 V)

Power consumption

- SIREC DM 50 VA
- SIREC DH 50 VA

Line frequency

47 ... 64 Hz

Safety and EMC standards

Safety standard Corresponds to EN 61,010-1 (2001)

Noise immunity Corresponds to EN 61,326-1 (1997)

EC declaration of conformity No. 3540.000
CE marking: 07/03
Compliance with following directives: 89/336/EEC, 73/23/EEC

Technical specifications of options

Analog output

Updating interval 200 ms for channels

Quantity 2 or 4 channels

Type 4 ... 20 mA, 0 ... 20 mA, 0 ... 24 mA

Resolution < 0.0015% (16 bits D/A converter)

Accuracy $\pm 0,25\%$

Isolation 300 V DC

Alarm cards

Updating interval 200 ms for all alarms

Quantity

- 4 relay outputs
- 8 relay outputs / 8 digital inputs
- 16 I/O connections

Type

- 4 or 8 relays - NO/NC 3A 240 V AC/DC (not for inductive loads, with internal RC element)
- 16 I/O - 1A 24 V DC (not for inductive loads, with internal RC element)

Triggering of alarm Freely-programmable internal alarm level or rate of change

Terminal configuration

- 4 or 8 relays, (NO-C-NC)
- 16 inputs/outputs, SPDT (C-NO)

Interfaces, media, protocols

Interfaces Ethernet and/or RS232, RS485

Protocols

- Own protocol (Trendbus)
- Modbus
- FTP Internet protocol

Transmission media

- RS485 (2-wire or 4-wire system, electrically isolated)
- Ethernet
- RS232

Modbus

- Mode RTU slave
- Data types Reading and writing of data
- Wiring 4-wire system (for RS485)

Mathematical functions (option)

Addition SIN

Subtraction COS

Multiplication TAN

Division Conversion from °F into °C

Square Conversion from °C into °F

Square root Running mean value

Modulo Lag

Log Index: analog signal

LN (Napierian logarithm) Index: digital I/O

Minimum Index: relay output

Maximum Evaluation

Rounding-off Exponent

Reciprocal value Lower limit

Absolute value Upper limit

Total Cold junction compensation

Above Alarm counter

Below Digital counter

Within Event counter

Outside User-defined counters

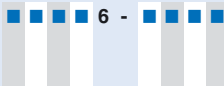
Selection and Ordering Data	Order No.
SIREC DM display recorder ^{A)} Front dimensions: 144 mm x 144 mm, for all applications, data memory: 1.44 MB diskette drive with slot for PC card	7ND4 420- 
Power supply • 50 or 60 Hz, 90 ... 240 V AC • 24 V DC	▶ 1 4
Signal inputs • Fast sampling card 200 ms for mA, V, mV, 500 ms for TC/RTD/R (20 ms also possible for 8 analog inputs and measured variables mA/V/mV) - 8 inputs, without analog outputs - 8 inputs, 2 analog outputs - 8 inputs, 4 analog outputs - 12 inputs, without analog outputs - 16 inputs, without analog outputs • Universal card high EMC, universal inputs (mA, mV, V, TC, RTD), sampling interval 500 ms - 8 inputs, without analog outputs - 8 inputs, 2 analog outputs - 8 inputs, 4 analog outputs - 12 inputs, without analog outputs - 16 inputs, without analog outputs	▶ A B C D E P Q R S T
Switching outputs and inputs • None • 8 relays, of which 2 can be optionally configured as binary input (240 V) • 8 binary outputs and inputs (24 V relay / freely-configurable) • 16 binary outputs and inputs (24 V relay / freely-configurable)	▶ A C D E
Interface • Ethernet (real-time Trendbus, Web, FTP, e-mail, Modbus) • Ethernet / RS232 / RS485 (real-time Trendbus, Web, FTP, e-mail, RS232 barcode) • RS485 (Modbus)	▶ 1 2 4
Transmitter power supply • None • 24 V max. 100 mA	▶ 1 2
Firmware options • None • Mathematical functions and 8 additional recording channels • Event marking • Mathematics + summation + 8 additional recording channels • Mathematics + summation + 8 additional recording channels + event marking • Mathematics + summation + 16 additional recording channels + event marking	▶ A B D E H K
Device version • Normal version with 4 MB RAM • Earthquake-proof version with 4 MB RAM • Normal version with 8 MB RAM (required with "Customized display") • Earthquake-proof version with 8 MB RAM (required with "Customized display") • ESS (FDA directive 21 CFR Part 11), with 8 MB RAM	▶ A B D E F
Documentation • Manual in German • Manual in English	▶ 1 2

Selection and Ordering Data	Order No.
SIREC DH display recorder ^{A)} Front dimensions: 300 mm x 300 mm, for all applications, data memory: 1.44 MB diskette drive with slot for PC card	7ND4 460- 
Power supply • 50 or 60 Hz, 90 ... 240 V AC • 24 V DC	▶ 1 4
Signal inputs • Fast sampling card 200 ms for mA, V, mV, 500 ms for TC/RTD/R (20 ms also possible for 8 analog inputs and measured variables mA/V/mV) - 16 inputs, without analog outputs - 24 inputs, without analog outputs - 24 inputs, 4 analog outputs - 32 inputs, without analog outputs • Universal card high EMC, universal inputs (mA, mV, V, TC, RTD), sampling interval 500 ms - 24 inputs, without analog outputs - 24 inputs, 4 analog outputs - 32 inputs, without analog outputs	▶ D G H K U V W
Switching outputs and inputs • None • 8 relays, of which 2 can be optionally configured as binary input (240 V) • 8 binary outputs and inputs (24 V relay / freely-configurable) • 16 binary outputs and inputs (24 V relay / freely-configurable) • 8 relays (240 V) / 16 binary outputs and inputs (24 V relays / freely-configurable) • 32 binary outputs and inputs (24 V relay / freely-configurable)	▶ A C D E F G
Interface • Ethernet (real-time Trendbus, Web, FTP, e-mail, Modbus) • Ethernet / RS232 / RS485 (real-time Trendbus, Web, FTP, e-mail, RS232 barcode, Modbus) • RS485 (Modbus)	▶ 1 2 4
Transmitter power supply • None • 24 V max. 1000 mA	▶ 1 2
Firmware options • None • Mathematical functions + summation + event recording + 32 additional recording channels	▶ A H
Device version • Normal version • Earthquake-proof version • ESS (FDA directive 21 CFR Part 11)	▶ A B C
Documentation • Manual in German • Manual in English	▶ 1 2

▶ Available ex stock

A) Subject to export regulations AL:N, ECCN: EAR99

Scope of delivery:
 Recorder, CD-ROM with manual in German, English and French, SIREC D software (SIREC D-Viewer), memory card drive.
 Note: PC card is not included in the scope of delivery

SIREC D display recorder

SIREC DM and SIREC DH

Accessories

Order No.

Firmware options for SIREC DM
Code No. of recorder required

Mathematical functions and 8 additional recording channels

7ND4 800-8AC

Summation

7ND4 800-8BC

Event marking

7ND4 800-8CC

Mathematics + summation + 8 additional recording channels

7ND4 800-8DC

Mathematics + summation + event marking + 8 additional recording channels

7ND4 800-8GC

ESS (FDA directive 21 CFR Part 11)

7ND4 800-8HC

Firmware options for SIREC DH
Code No. of recorder required

Mathematical functions and 8 additional recording channels

7ND4 800-8AB

Summation

7ND4 800-8BB

Event marking

7ND4 800-8CB

Mathematics + summation + event marking + 32 additional recording channels

7ND4 800-8GB

ESS (FDA directive 21 CFR Part 11)

7ND4 800-8HB

Options / enabling of SIREC D software
Code No. of software required

Enabling of SIREC D-Manager

7ND4 800-8BA

Enabling of SIREC D-Server

7ND4 800-8CA

Enabling of SIREC D-Designer

7ND4 800-8DA

Upgrading of SIREC D-Manager to SIREC D-Server

7ND4 800-8EA

Software
Only for subsequent orders; software is included in delivery of recorder

SIREC D software

Evaluation software for SIREC DS/DM/DH (on CD) incl. enabling for SIREC D-Viewer and manual for the software on CD in German, English, French

7ND4 800-8AA

Documentation
Included on CD-ROM in scope of delivery

SIREC DM and SIREC DH recorder manual

• German (can also be downloaded from Internet)

A5E00117344

• English (can also be downloaded from Internet)

A5E00117345

• French (can only be downloaded from Internet)

Options

Hardware options

- 2 or 4 analog outputs (4 to 20 mA) for output of analog signals or calculated results from the mathematical functions (analog outputs only possible together with a reduced number of signal inputs).
- 8 relay outputs, freely-assignable function. In the case of 8 outputs, the binary outputs 7 and 8 can also be used as binary inputs. With SIREC DH, this option is possible 2 x.
- 8 or 16 binary outputs, freely-assignable function. The binary outputs can also be used as binary inputs. With SIREC DH, this option is possible 2 x.
- Transmitter power supply for two-wire transmitters or as power source for the binary inputs and outputs.

Firmware options

- Summation (total quantity) of a channel over an adjustable interval
- Mathematical functions for calculations
- Additional recording channels, up to 16 (SIREC DM) or 32 (SIREC DH) for display of mathematical operations/results
- Internal control functions (event markers) for monitoring process events. These can trigger e.g. markers in the recording, control functions or counter functions.

Dimensional drawings

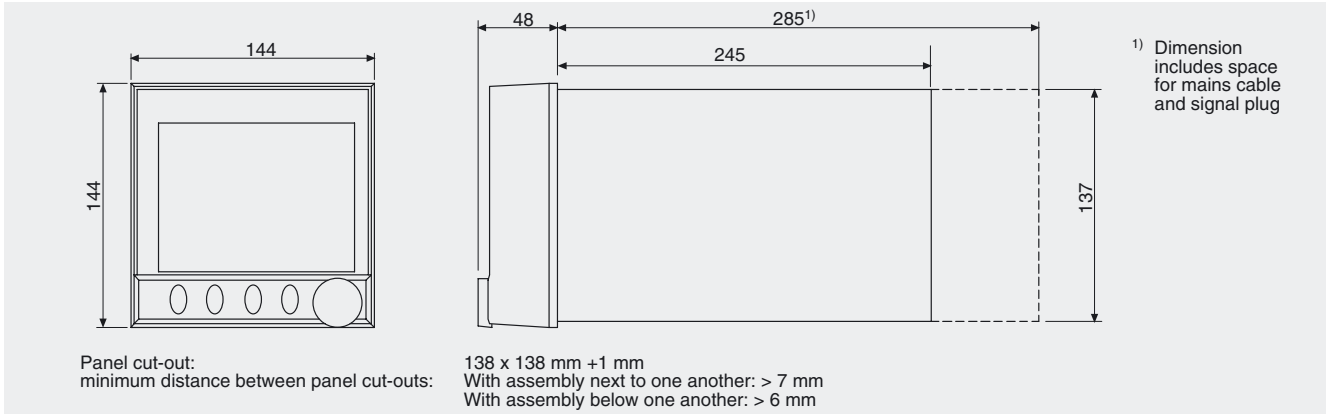

SIREC DM, dimensions

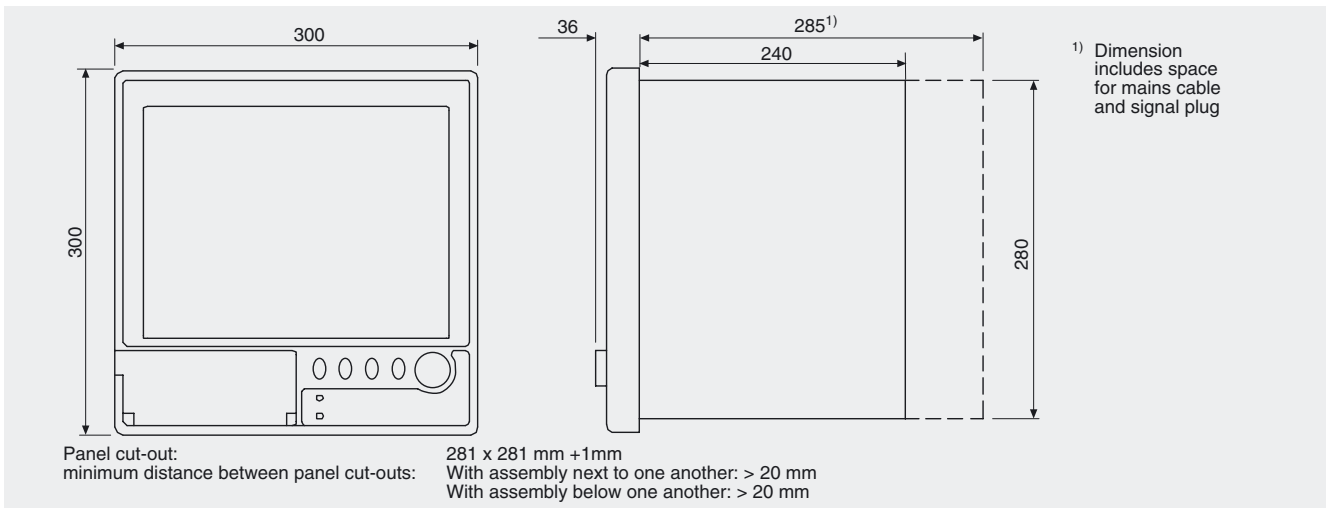

SIREC DH, dimensions

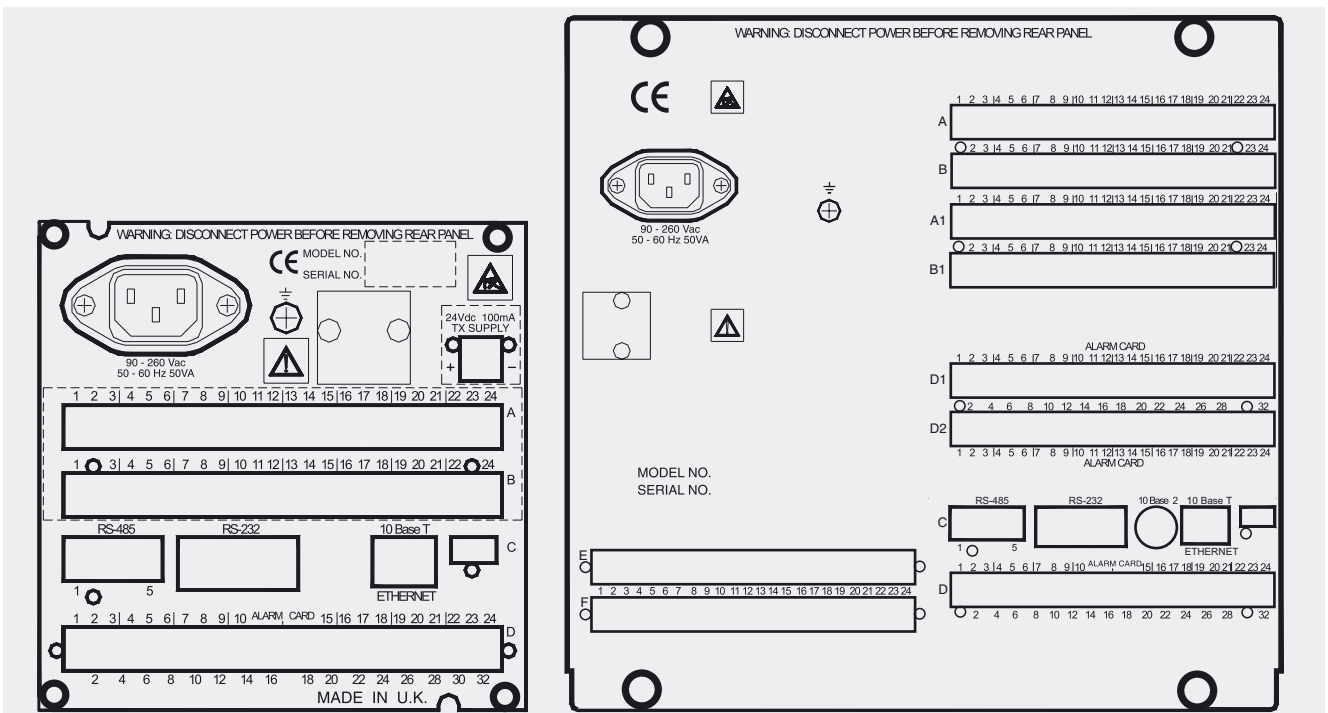

AC rear of SIREC DM (left) and SIREC DH (right)